

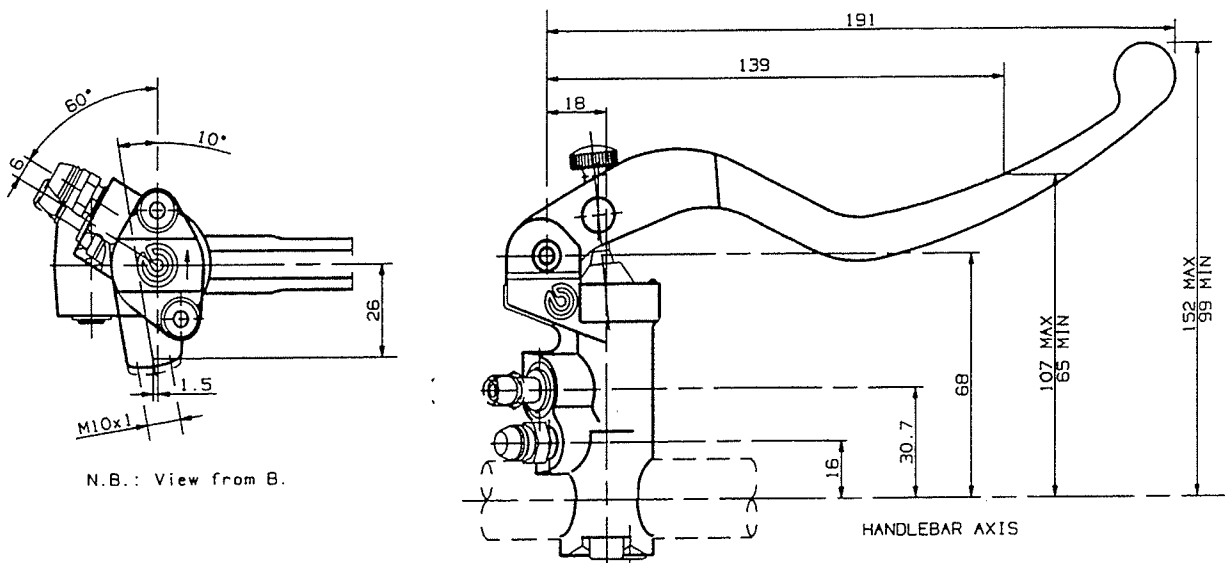

FRONT MASTER CYLINDER

PR 19 B

10.4760.70



N.B.: View from B.

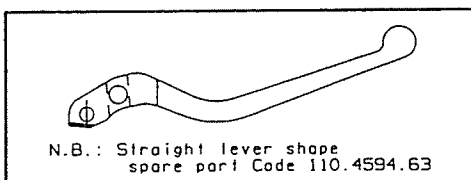

N.B.: Straight lever shape
spare part Code 110.4594.63

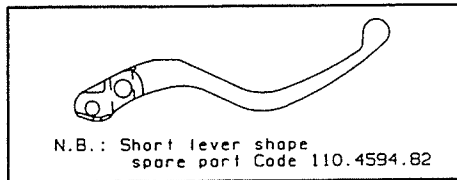

N.B.: Short lever shape
spare part Code 110.4594.82

DESCRIPTION

Front master cylinder without incorporated reservoir, machined by forging.
Possibility to adjust lever opening.
Construction Material: Aluminium Alloy
Hard Oxidation.
Operating fluid: fluid broke DOT4.
Master cylinder equipped with lever
Code 110.4594.61

Master cylinder
BODY color: Racing Color.
Master cylinder
LEVER color: Black Anodic Oxidation.

TECHNICAL CHARACTERISTICS

Piston diameter: 19.0 mm
Weight: 0.306 Kg
Distance between centers: 18.0 mm

AVAILABLE SPARE PARTS

SPARE PARTS CODE	LONG LEVER	STRAIGHT LEVER	SHORT LEVER	PUSH-ROD KIT
10.4760.70	110.4594.61	110.4594.63	110.4594.82	110.4266.60

Indicating informations subject to modification.
For further specifications contact Technical Section.

LAST UPDATE: 05/07/1994