

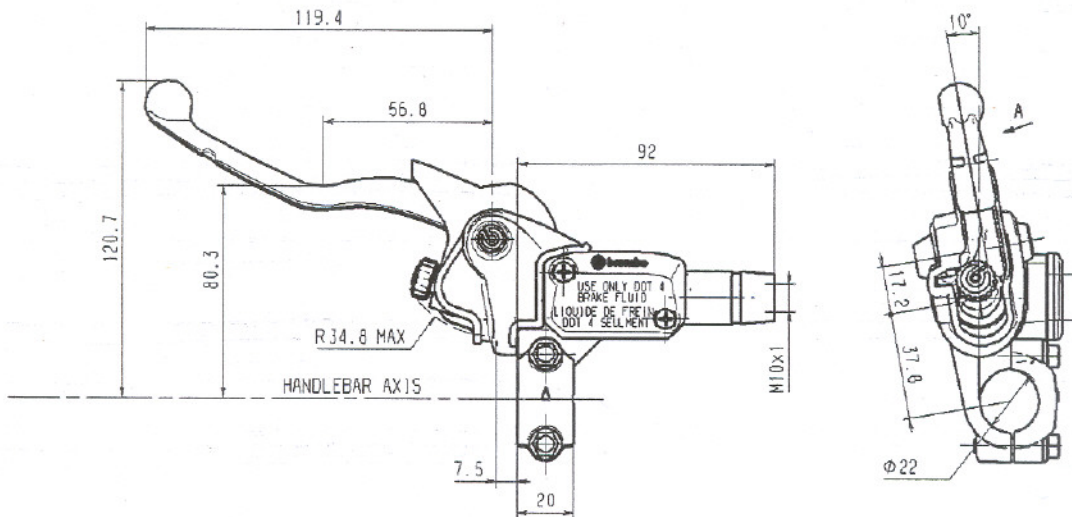

FRONT CLUTCH MASTER CYLINDER

PS 10/17.7

10.9203.10



Note: Lever dimensions refer to view from A

DESCRIPTION

Front master cylinder with incorporated reservoir.

Construction material: aluminium alloy.

Operating fluid: brake fluid DOT 3 ÷ DOT 4.

Master cylinder BODY color: anodic oxidation black colour

Master cylinder LEVER color: polished

TECHNICAL CHARACTERISTICS

Piston diameter:	10 mm
Weight:	0.32 kg
Usable reservoir volume:	7 cm ³
Maximum volume increase for clutch wear:	1.8 cm ³

AVAILABLE SPARE PARTS

SPARE PARTS PUMP CODE	LEVER	CLAMP	CAP	LEVER PIN	PISTON
10.9203.10	110.2706.06	110.4372.27	110.2704.78	105.5474.80	110.4623.98

DUST COVER	ANTI-BUBBLE	ROD	SPRING GUIDE
110.3530.60	110.4771.10	110.4266.28	110.4265.05

BEWARE: SPARE PISTON AVAILABLE ONLY FOR ALLOWED CUSTOMERS

Indicating informations subject to modification.
For further specifications contact Technical Section.

LAST UPDATE: 11/06/07