

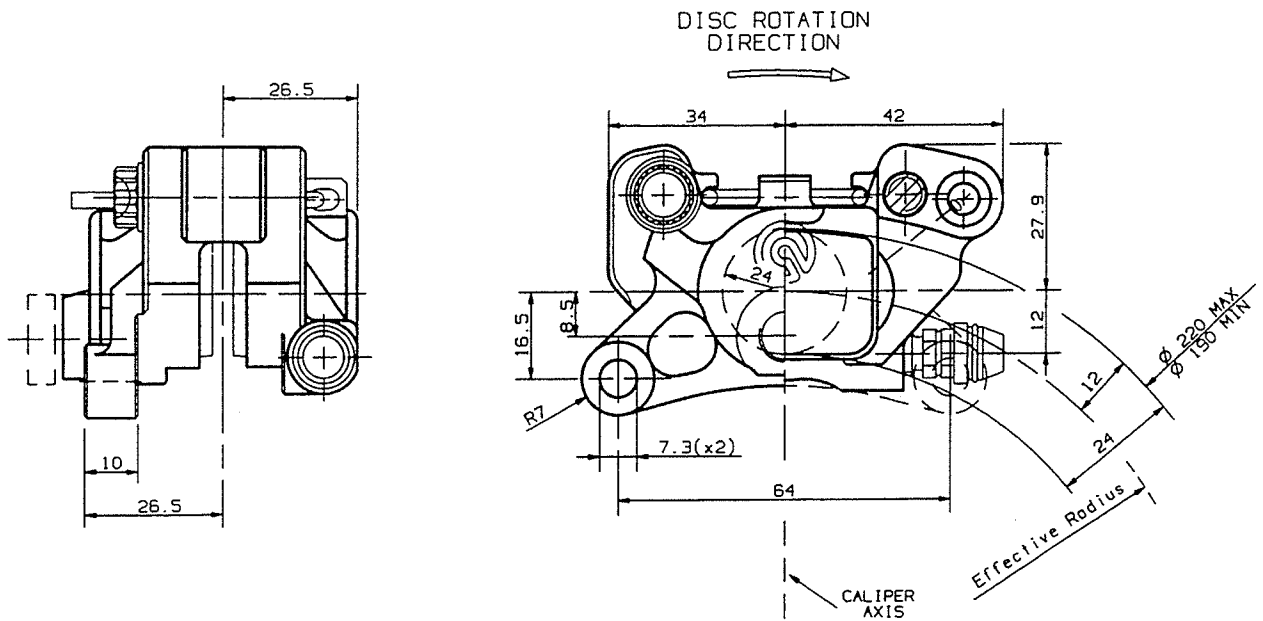

# FIXED CALIPER

P2.24

X 2.060.01 C



## DESCRIPTION

Fixed caliper with 2 opposed pistons, realized by semicalipers joined by bolts. Pads are supported by one clip which allows a quickly pads remove.  
 Construction Material: Aluminium Alloy  
 Hard Oxidation.  
 Operating fluid: brake fluid DOT4.

## PADS SHAPE AND DIMENSIONS

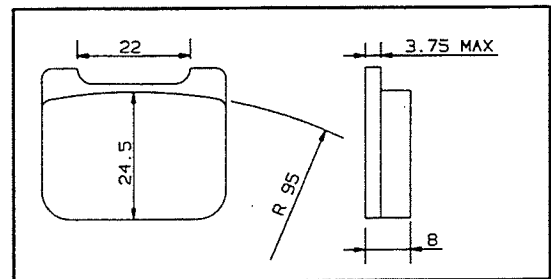

## TECHNICAL CHARACTERISTICS

Piston number and diameter:	2	24 mm	Average pad surface (1 pad):	8.0 cm <sup>2</sup>
MAX working pressure:		40 bar	Weight (with sintered pads):	0.198 Kg

## CONFIGURATION

CHARACT. CODE CALIPER	BODY COLOR	MOUNT. SIDE	USABLE DISCS THICKNESS
X 2.060.01	RACING	SX	6.0 mm (carbon disc) 4.0 mm (steel disc)

## AVAILABLE SPARE PARTS

SPARE PARTS CODE CALIPER	BLEEDER SCREW	BOOTS	PADS/MATERIAL	PADS/MATERIAL
X 2.060.01	X 1.017.44	105.1502.10	107.6930.70 (FRENO 222)	107.6930.71 (MIBA)

Indicating informations subject to modification. For further specifications contact Technical Section.

LAST UPDATE: 19/01/1994