



ATTENZIONE: Il montaggio del prodotto deve essere eseguito da personale specializzato
WARNING: The mounting of the product it must be realized from staff specialist

LEGENDA / LEGEND

Bloccare con frenafili: L= Leggera - M= Media - S= Forte
 Lock with the threadlocker: L= Light - M= Medium - S= Strong

Lubrificare ✓ / Lubricate ✓
 Non lubrificare ✗ / Do not lubricate ✗
 Solo primi filetti ◆ / First threads only ◆

Pulire e/o sgrassare
 Clean and/or degrease

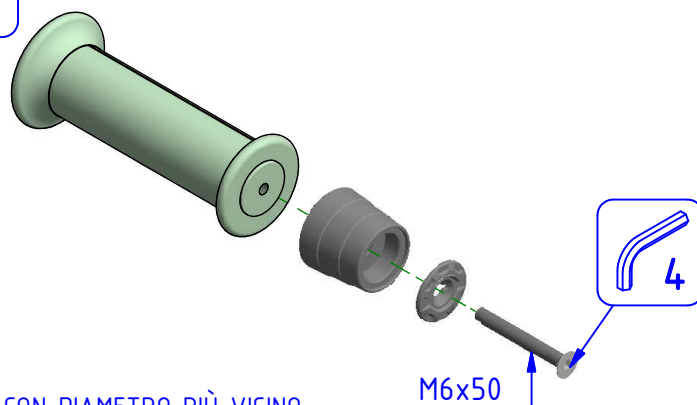
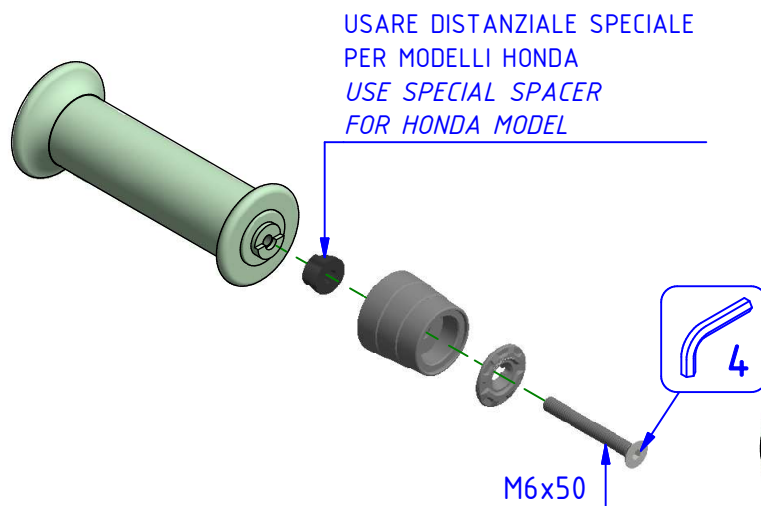
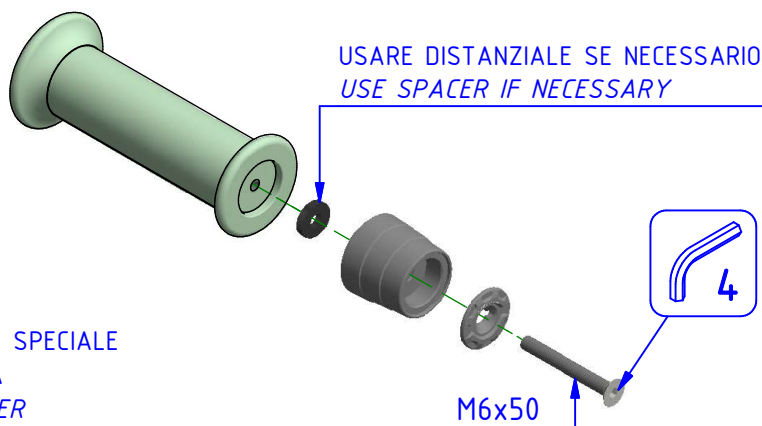

* Lubrificare leggermente la sede di battuta per la testa della vite.
 * Lightly grease the abutment seat for the head of the screw.



ATTENZIONE: Questo prodotto potrebbe non essere conforme al codice stradale o alle leggi vigenti in alcuni paesi e quindi utilizzabili solo in aree private e/o chiuse al traffico
WARNING: This product may not comply with local road rules and regulations and can be used only in private areas and/or areas closed to traffic.



ART:
 CM238

ISTRUZIONI / INSTRUCTIONS

CONTRAPPESI MANUBRIO
 HANDLEBAR WEIGHT

A termini di legge ci riserviamo la proprietà di questo disegno con divieto di riproduzione o di renderlo noto a terzi senza nostra autorizzazione. / Pursuant to law, we reserve the ownership of this drawing with prohibition to copy or disclosed to third parties without our authorization.
 CNC RACING si riserva il diritto, a sua esclusiva discrezione, di apportare modifiche al prodotto e a queste informazioni in qualsiasi momento e senza preavviso. / CNC RACING reserves the right, in its sole discretion, to modify the product and this information at any time without prior notice.

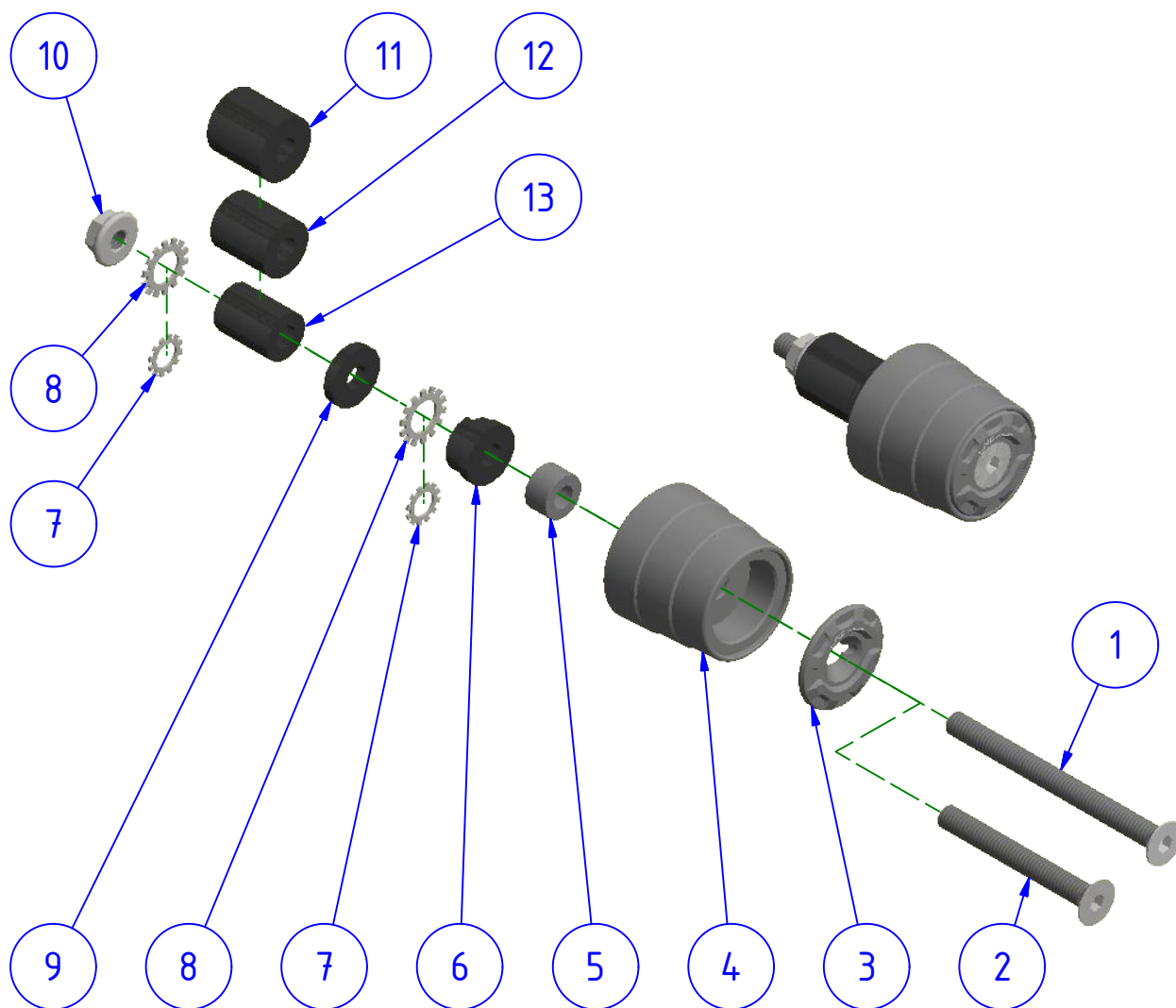

POS.	QTÀ	NUMERO PARTE	DESCRIZIONE	DESCRIPTION
1	2	YC01204194Y	VITE	SCREW
2	2	YC01204154Y	VITE	SCREW
3	2	YP001020010	TAPPO	CUP
4	2	YP000183010	CONTRAPPESO	HANDLEBAR WEIGHT
5	2	YP000628010	DISTANZIALE	SPACER
6	2	YC112040301	PARTICOLARE IN GOMMA	RUBBER PART
7	4	YC052100111	RONDELLA	WASHER
8	4	YC052120111	RONDELLA	WASHER
9	2	YC112040200	PARTICOLARE IN GOMMA	RUBBER PART
10	2	YC023040012	DADO	NUT
11	2	YC112010300	PARTICOLARE IN GOMMA	RUBBER PART
12	2	YC112010200	PARTICOLARE IN GOMMA	RUBBER PART
13	2	YC112010100	PARTICOLARE IN GOMMA	RUBBER PART



ATTENZIONE: Questo prodotto potrebbe non essere conforme al codice stradale o alle leggi vigenti in alcuni paesi e quindi utilizzabili solo in aree private e/o chiuse al traffico
 WARNING: This product may not comply with local road rules and regulations and can be used only in private areas and/or areas closed to traffic.



ART:

CM238

ELENCO PARTI / PARTS LIST

CONTRAPPESI MANUBRIO
 HANDLEBAR WEIGHT