



ATTENZIONE: Il montaggio del prodotto deve essere eseguito da personale specializzato
WARNING: The mounting of the product it must be realized from staff specialist

LEGENDA / LEGEND



Bloccare con frenafilletti: L= Leggera - M= Media - S= Forte
 Lock with the threadlocker: L= Light - M= Medium - S= Strong

*OEM = ORIGINAL EQUIPMENT MANUFACTURER



Immagine usata a fini esclusivamente illustrativi
 Image used for illustrative purposes only

** PER IL SERRAGGIO DELLE VITI RIFARSI AL MANUALE DEL COSTRUTTORE
 ** FOR THE TIGHTENING OF THE SCREWS REFER TO THE MANUFACTURER'S MANUAL



ATTENZIONE: Questo prodotto potrebbe non essere conforme al codice stradale o alle leggi vigenti in alcuni paesi e quindi utilizzabili solo in aree private e/o chiuse al traffico
WARNING: This product may not comply with local road rules and regulations and can be used only in private areas and/or areas closed to traffic.

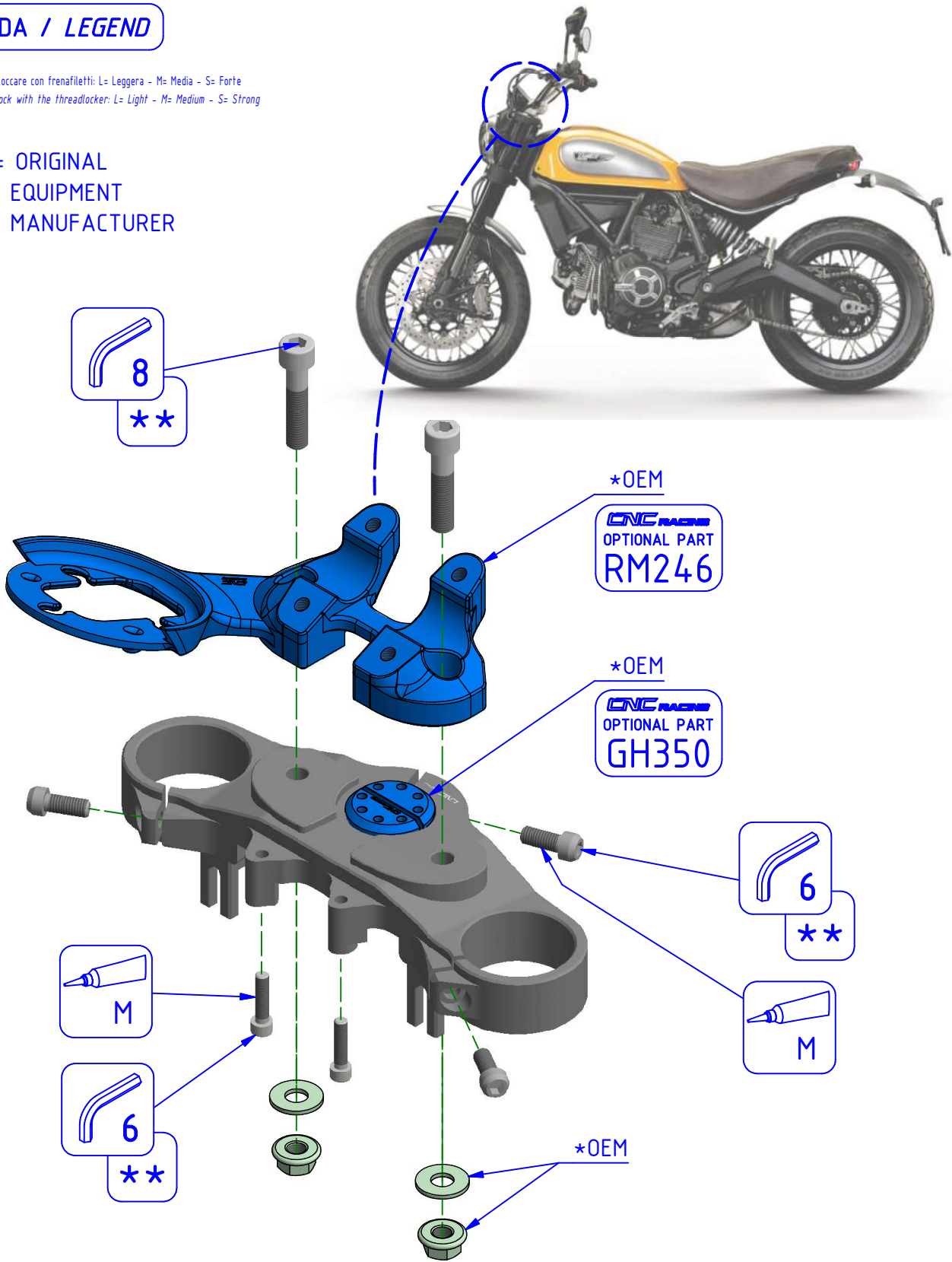

ART:
 PST09

ISTRUZIONI / INSTRUCTIONS
 PIASTRA DI STERZO SUPERIORE
 TOP YOKE

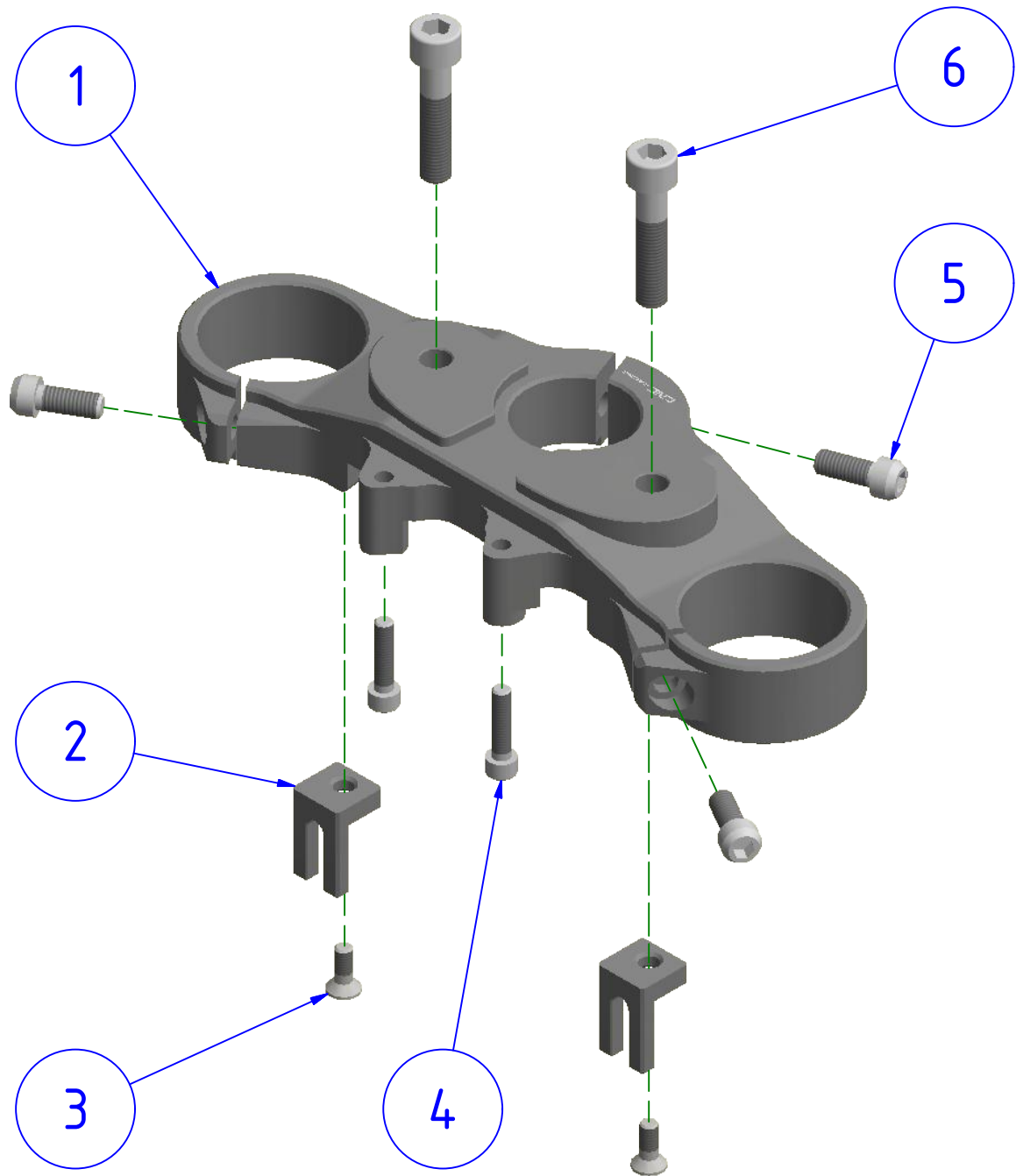

POS.	QTÀ	NUMERO PARTE	DESCRIZIONE	DESCRIPTION
1	1	YP000410010	TESTA DI STERZO	STEERING HEAD
2	2	YP001267010	STAFFA	BRACKET
3	2	YC012040722	VITE	SCREW
4	2	YC011041012	VITE	SCREW
5	3	YC01106094A	VITE	SCREW
6	2	YC011271432	VITE	SCREW



ATTENZIONE: Questo prodotto potrebbe non essere conforme al codice stradale o alle leggi vigenti in alcuni paesi e quindi utilizzabili solo in aree private e/o chiuse al traffico
 WARNING: This product may not comply with local road rules and regulations and can be used only in private areas and/or areas closed to traffic.



ART:
PST09

ELENCO PARTI / PARTS LIST

PIASTRA DI STERZO SUPERIORE
TOP YOKE