

**Schutz- und Zierbügel
YAMAHA XV 1900 Midnight Star**

**Artikel-Nummer:
501.4517 chrom**

Seitenkoffer
Topcases
Gepäckträger
Lock it System
Softbags
Aluminiumkoffer
Lederkoffer
Schutzbügel
Hauptständer
Chopper-Parts
Quad-Parts
Accessoires



Montage

Stück	Bestellnr.	Bezeichnung
1	704.505	Schutz-/Zierbügel
2	151.073	Bügelschellen M 8 x 32 x 55 mm
4	150.895	Hutmuttern M 8
4	150.810	U-Scheiben ø8,4
4	151.074	Sprengringe ø8,4
4	150.795	Inbusschrauben M 10 x 85 Festigkeit 10.9
8	150.811	U-Scheiben ø10,5
4	150.801	selbstsichernde Muttern M 10
1	270.109	Moosgummi 20 cm
1	151.075	Aludistanz ø20 x ø11 x 23 mm
1	151.076	Aludistanz ø20 x ø11 x 15 mm

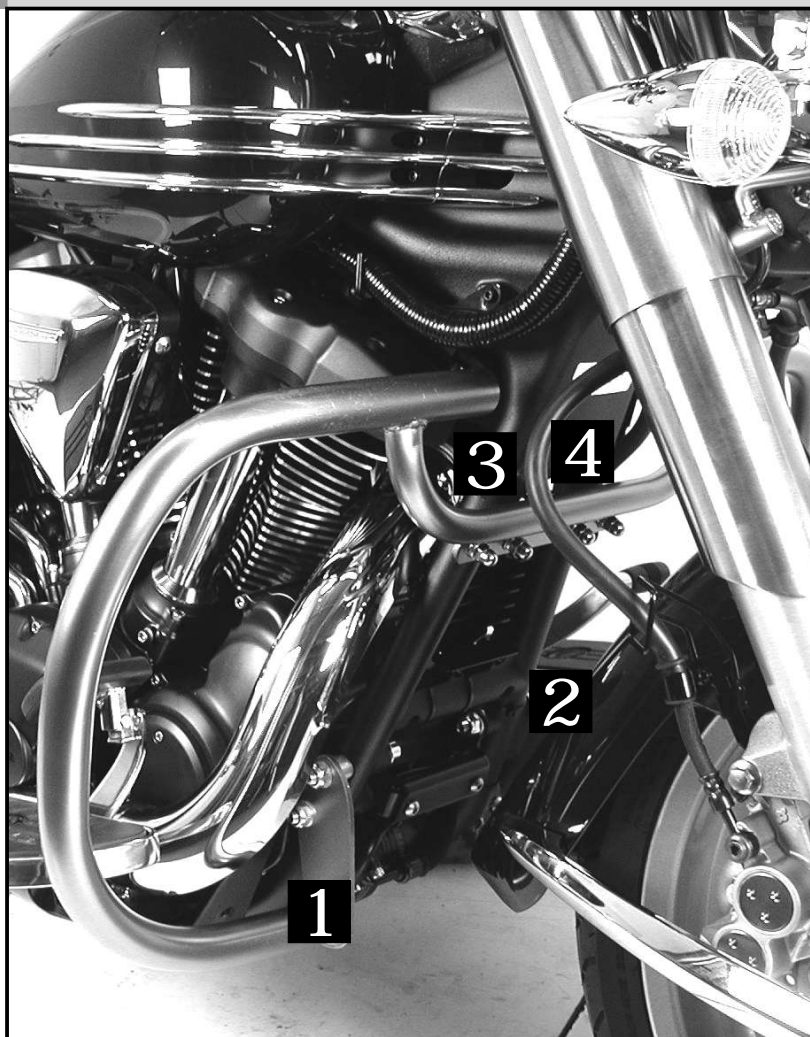

**Nach der Montage alle Verschraubungen auf festen Sitz kontrollieren!
Bitte beachten Sie unsere beigefügten Serviceinformationen.**

Als weiteres Zubehör lieferbar:

- 650.4517 00 02 Kofferträger schwarz "Lock it System" (abnehmbar)
- 650.4517 01 02 Gepäckbrücke chrom
- 625.4517 Packtaschenhalter
- 400.4517 Twinlight - Set
- 600/611.4517 Sissybar ohne/mit Gepäckbrücke



**Hepco & Becker GmbH
An der Steinmauer 6
D-66955 Pirmasens**

**Tel.: 06331 - 1453 - 100
Fax: 06331 - 1453 - 120
eMail: vertrieb@hepco-becker.de
www.hepco-becker.de**

Schutz- und Zierbügel
YAMAHA XV 1900 Midnight Star

Artikel-Nummer:
501.4517 chrom

- Seitenkoffer
- Topcases
- Gepäckträger
- Lock it System
- Softbags
- Aluminiumkoffer
- Lederkoffer
- Schutzbügel
- Hauptständer
- Chopper-Parts
- Quad-Parts
- Accessoires



Montage

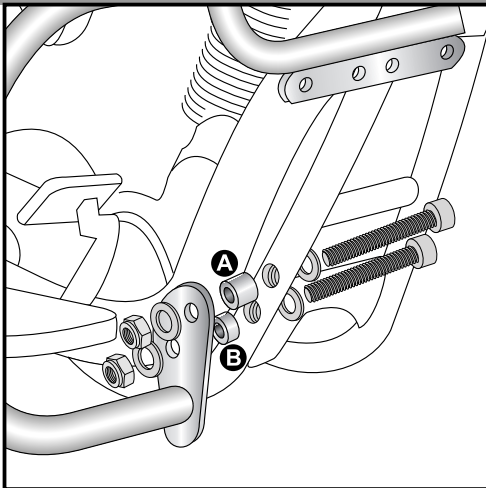

1 rechte Seite

Die Montage erfolgt an der Motoraufhängung. Hierzu die Originalschrauben demontieren; diese entfallen.

Befestigung rechts:

Über die freien Rahmenbohrungen werden von außen als Abstandshalter Aludistanzen geschoben.

Oben: $\varnothing 20 \times \varnothing 11 \times 23$ mm / Unten: $\varnothing 20 \times \varnothing 11 \times 15$ mm
Die Verschraubung erfolgt mit den Inbusschrauben M 10 x 85
nebst U-Scheiben $\varnothing 10,5$ und selbstsichernden Muttern M 10.

Die Inbusschrauben von innen nach außen montieren.

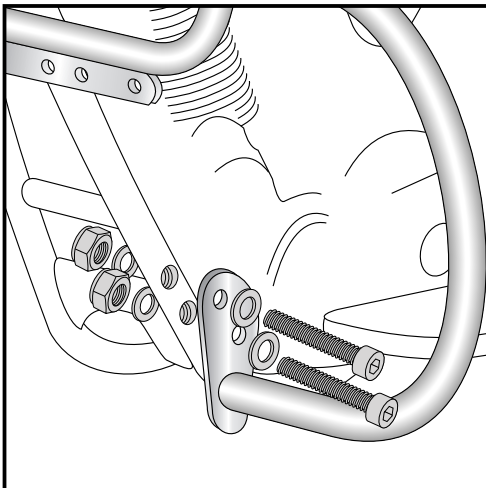
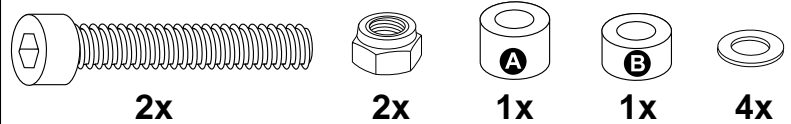

2 linke Seite

Die Montage erfolgt an der Motoraufhängung. Hierzu die Originalschrauben demontieren; diese entfallen.

Befestigung links:

Die Lasche des Schutz- und Zierbügels direkt über den freien Rahmenbohrungen platzieren. Die Verschraubung erfolgt mit den Inbusschrauben M 10 x 85 nebst U-Scheiben $\varnothing 10,5$ und selbstsichernden Muttern M 10.

Die Inbusschrauben von außen nach innen montieren.

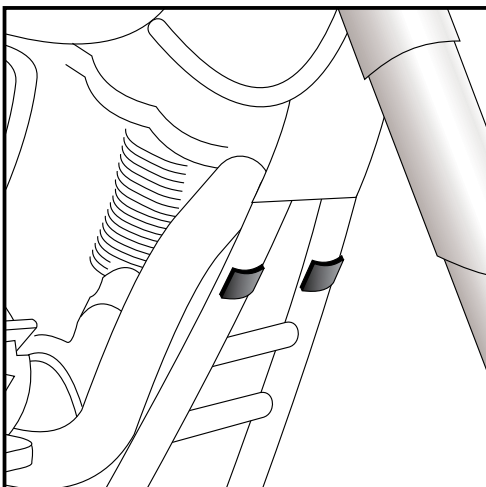

3 Befestigung oben:

Zuerst an der Auflagefläche des Schutz- und Zierbügels am Rahmen den Moosgummi aufkleben.

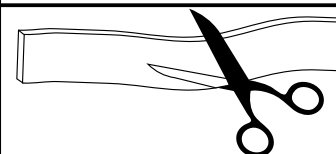

270.109
Moosgummi

Schutz- und Zierbügel
YAMAHA XV 1900 Midnight Star

Artikel-Nummer:
501.4517 chrom

Seitenkoffer
Topcases
Gepäckträger
Lock it System
Softbags
Aluminiumkoffer
Lederkoffer
Schutzbügel
Hauptständer
Chopper-Parts
Quad-Parts
Accessoires



Montage

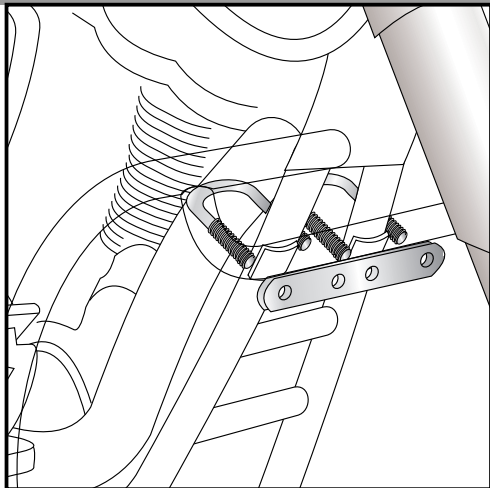

4

Befestigung oben:

Diese erfolgt mit den Bügelschellen M 8 x 32 x 55 mm
direkt am Rahmen.

Die Verschraubung mit Hutmuttern M 8 nebst U-Scheiben
ø 8,4 und Sprengringen ø8,4.

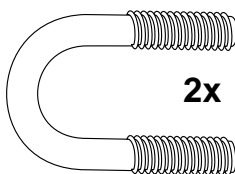
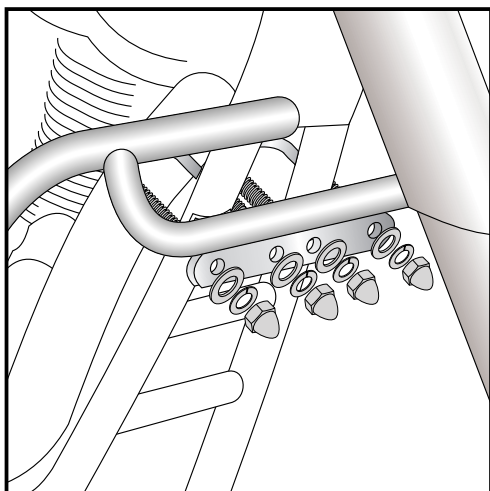

2x



4x



4x



4x

Engine guard
YAMAHA XV 1900 Midnight Star

Item-No.
501.4517 chrome

Side cases
Top cases
luggage frames
Lock it system
Softbags
Aluminium luggage
Leather luggage
Protection bars
Center stands
Chopper parts
Quad parts
Accessories



Assembling instructions

Stück quant	Bestellnr. item no.	Bezeichnung description
1	704.505	engine guard
2	151.073	u-shaped clamp M 8 x 32 x 55 mm
4	150.895	cup nut M 8
4	150.810	washer ø8,4
4	151.074	lock ring ø8,4
4	150.795	allen screw M 10 x 85 Festigkeit 10.9
8	150.811	washer ø10,5
4	150.801	self-lock nut M 10
1	270.109	rubber buffer 20 cm
1	151.075	spacer ø20 x ø11 x 23 mm
1	151.076	spacer ø20 x ø11 x 15 mm

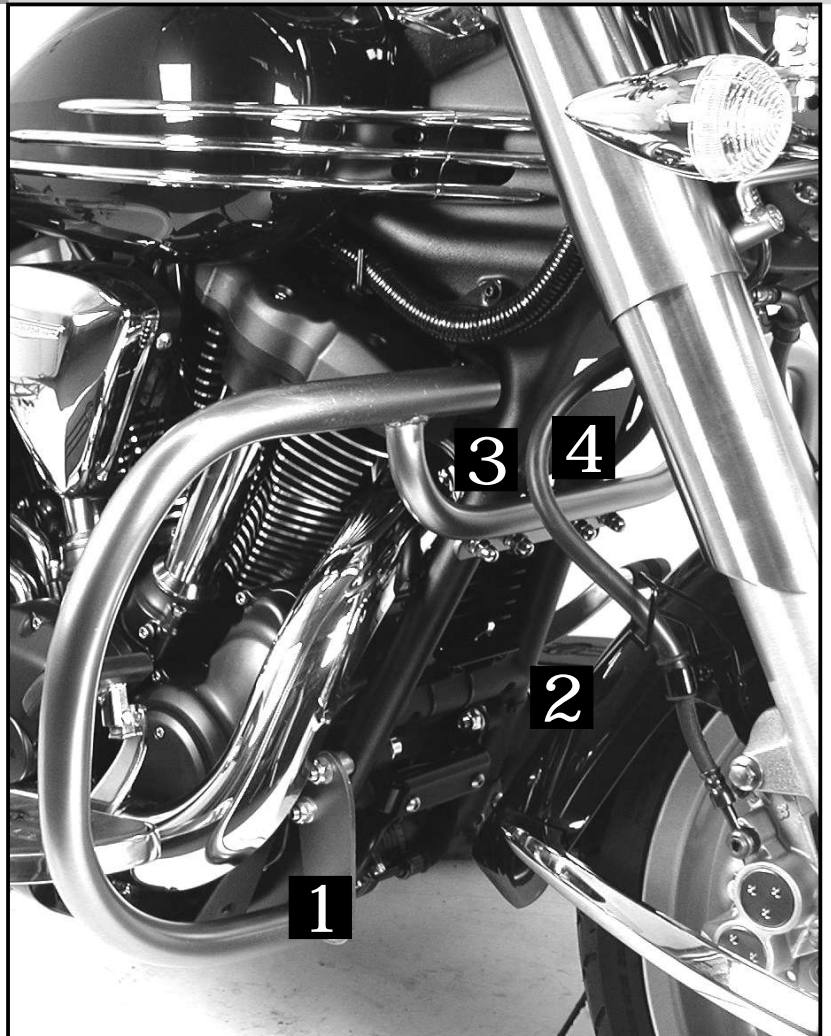

Control all screw connections after the assembling for tightness! Please notice our enclosed service information. All screws, bolts and nuts should be checked after driving the first 50 km to ensure that all are tightened to the proper torque. Medium strength liquid thread-locker (i.e., „Locktite“) should be used to secure all screws, bolts, and nuts.

Also available:
650.4517 00 02 Side carrier, black, "Lock it System" (removable)
650.4517 01 02 Rear rack chrome
625.4517 Leather bag holder
400.4517 Twinlight - Set
600/611.4517 Sissybar without/with rear rack



Hepco & Becker GmbH
An der Steinmauer 6
D-66955 Pirmasens
Germany

Tel.: +49 6331 - 1453 - 100
Fax: +49 6331 - 1453 - 120
eMail: vertrieb@hepco-becker.de
www.hepco-becker.de

Engine guard
YAMAHA XV 1900 Midnight Star

Item-No.
501.4517 chrome

- Side cases
- Top cases
- luggage frames
- Lock it system
- Softbags
- Aluminium luggage
- Leather luggage
- Protection bars
- Center stands
- Chopper parts
- Quad parts
- Accessories



Assembling instructions

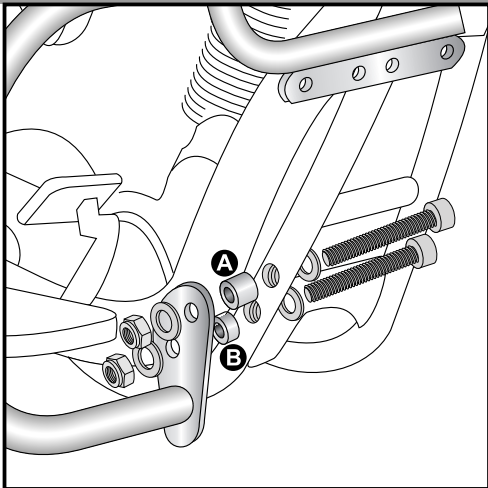

1 right side

For mounting, use engine suspension. Unmount original screws, they are not needed any more.

Fastening of the crash bar:

Sandwich spacer in the free threaded holes:

top: **A** $\varnothing 20 \times \varnothing 11 \times 23$ mm / Bottom: **B** $\varnothing 20 \times \varnothing 11 \times 15$ mm

Fix the crash bar with allen screws M 10 x 85, washers $\varnothing 10,5$ and self-lock nuts M 10.

Mount the allen screws from inside to outside - see picture.

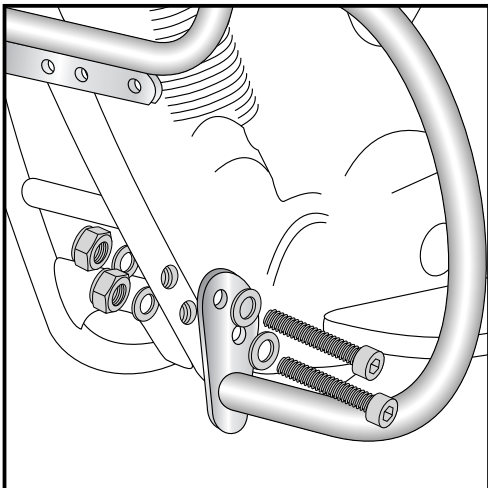
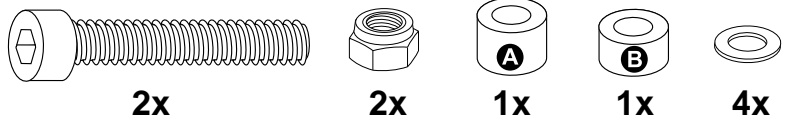

2 left side

For mounting, use engine suspension. Unmount original screws, they are not needed any more.

Fastening of the crash bar:

in the free threaded holes.

Fix the crash bar with allen screws M 10 x 85, washers $\varnothing 10,5$ and self-lock nuts M 10.

Mount the allen screws from inside to outside - see picture.

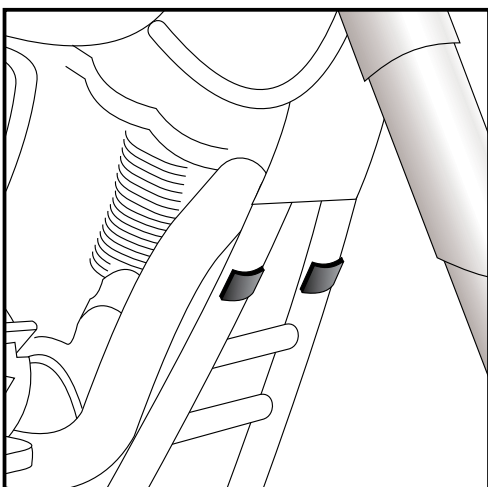

3 Preparing:

Stick the rubber buffer at the position of the frame, where the crash bar will have contact.

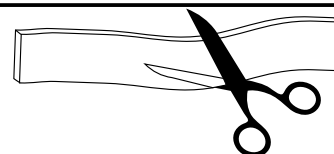

270.109
rubber buffer

Engine guard
YAMAHA XV 1900 Midnight Star

Item-No.
501.4517 chrome

Side cases
Top cases
luggage frames
Lock it system
Softbags
Aluminium luggage
Leather luggage
Protection bars
Center stands
Chopper parts
Quad parts
Accessories



Assembling instructions

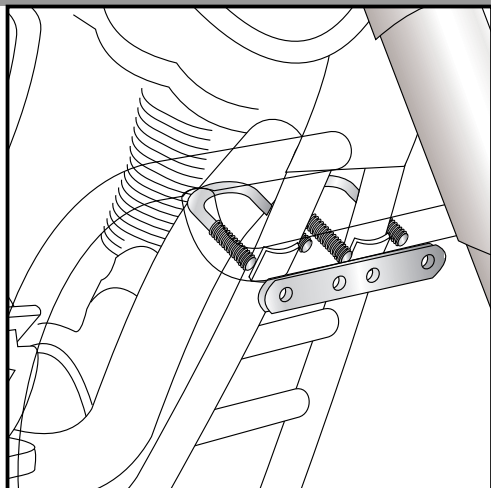

4

Fastening of the crash bar top:
with u-shaped clamp M 8 x 32 x 55 mm at the frame.
Fix it with cup nut M 8, washers \varnothing 8,4 and lock rings \varnothing 8,4.

