



## TANKRING

HONDA VFR 800 X CROSSRUNNER ab Baujahr 2015

Artikel-Nr.: 506.992

HONDA CRF 1000 Africa Twin ab Baujahr 2016

Artikel-Nr.: 506.994

Der Bausatz umfaßt die folgenden Teile:

Stück	Position	Bezeichnung
1		Montageset mit Tankring
2		Abdeckung Magnetdome
3	①	Senkkopfschraube M4x35
3	②	Aludistanz $\varnothing 7,5 \times \varnothing 4,5 \times 5,5$ mm

## Hinweis

Dieses Tankring-Kit ist für die HONDA VFR 800 X CROSSRUNNER ab Baujahr 2015 und CRF 1000 Africa Twin ab Baujahr 2016 geeignet.

## Montage

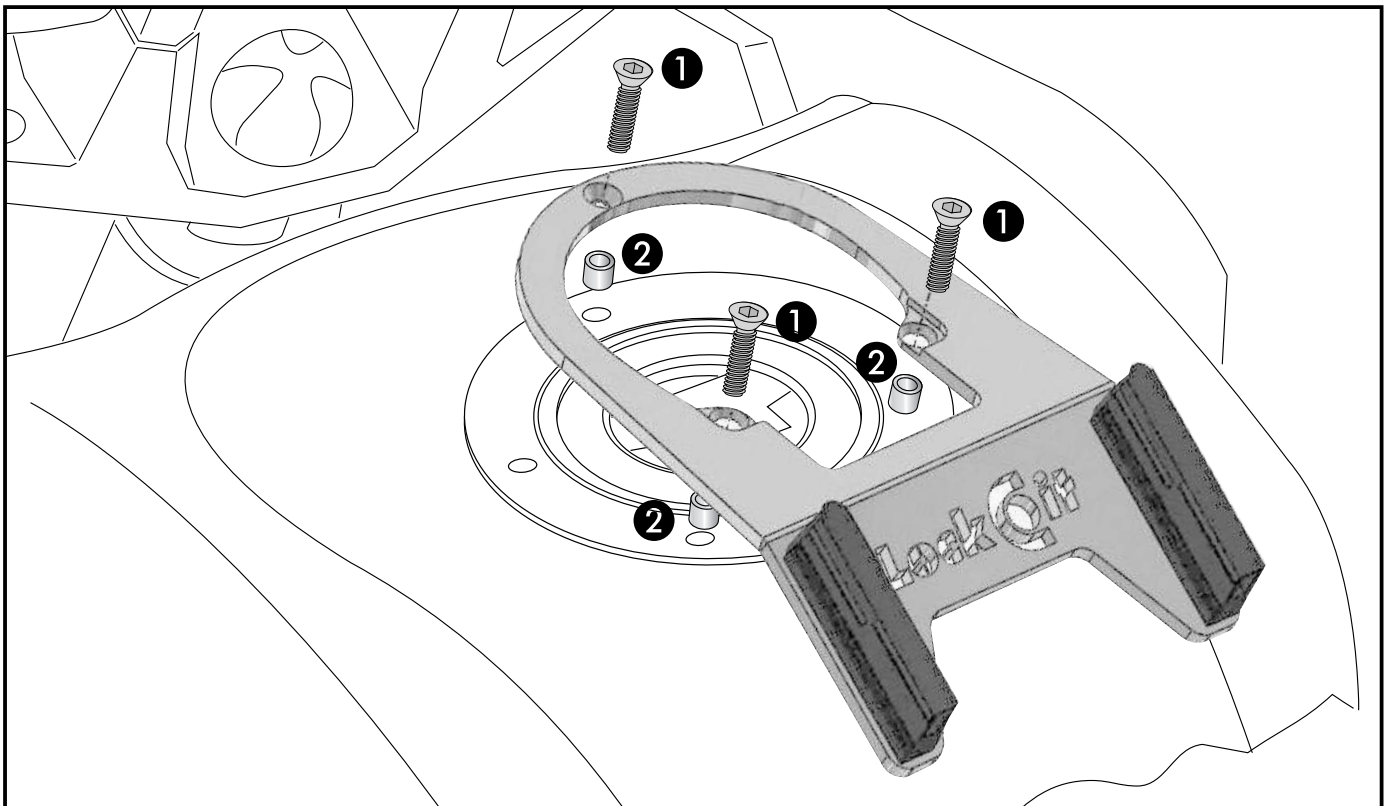

Anzugsmomente des Motorradherstellers beachten!

Nach der Montage alle Verschraubungen auf festen Sitz kontrollieren!



Hepco & Becker GmbH  
An der Steinmauer 6  
D-66955 Pirmasens

Tel.: 06331 - 1453 - 100  
Fax: 06331 - 1453 - 120  
eMail: [vertrieb@hepco-becker.de](mailto:vertrieb@hepco-becker.de)  
[www.hepco-becker.de](http://www.hepco-becker.de)



## TANKRING

HONDA VFR 800 X CROSSRUNNER from date of manufacture 2015

Item-no.: 506.992

HONDA CRF 1000 Africa Twin from date of manufacture 2016

Item-no.: 506.994

The kit includes the following parts:

Quant	Position	description
1		Mounting set with tank ring
2		Cover magnetic dome
3	①	Countersunk screw M4x35
3	②	Spacer with cone $\varnothing 7,5 \times \varnothing 4,5 \times 5,5$ mm

## NOTICE

This tank ring kit is suitable for HONDA VFR 800 X CROSSRUNNER from date of manufacture 2015 and CRF 1000 Africa Twin from date of manufacture 2016.

## Assembling instructions

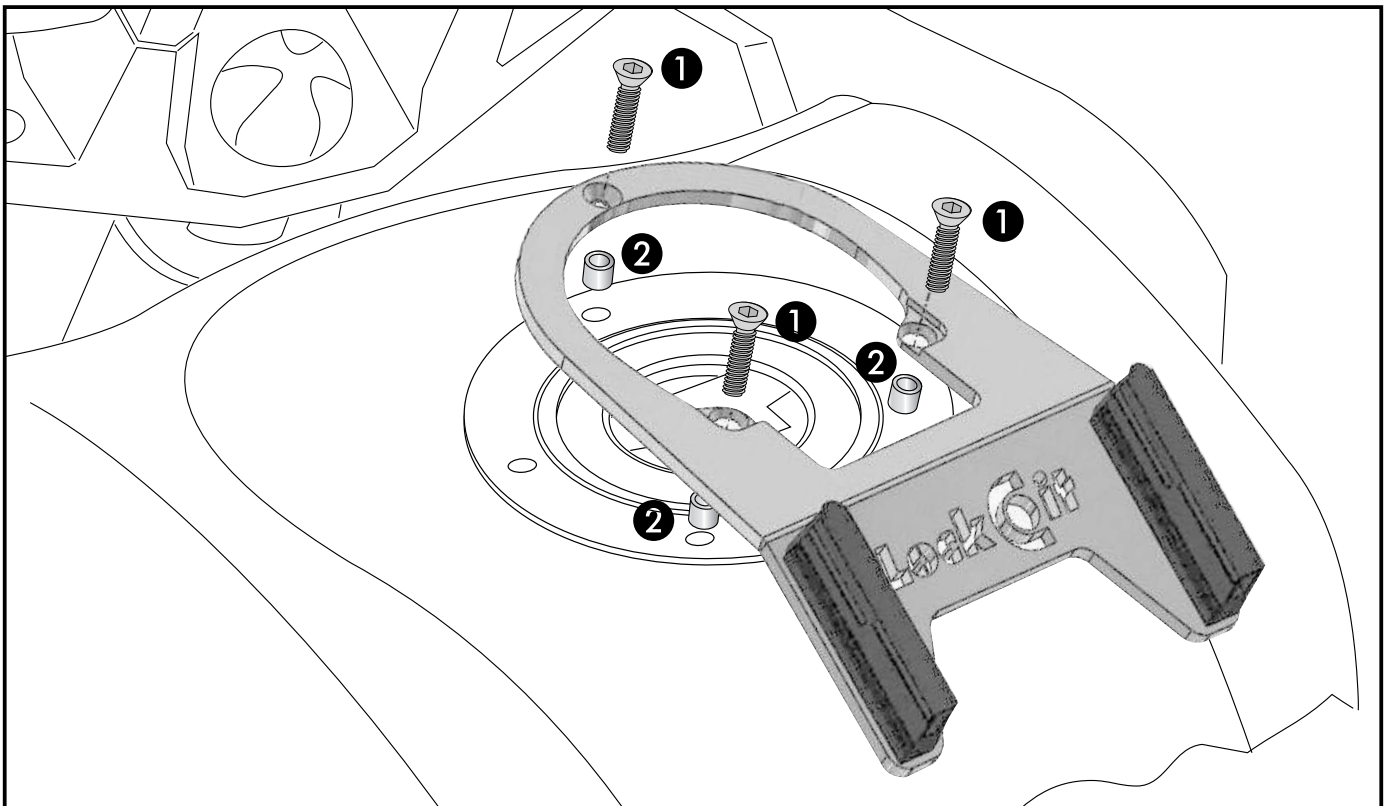

Observe the tightening torques of the motorcycle manufacturer!  
Control all screw connections after the assembling for tightness!



Hepco & Becker GmbH  
An der Steinmauer 6  
D-66955 Pirmasens  
Germany

Tel.: 0049 6331 - 1453 - 100  
Fax: 0049 6331 - 1453 - 120  
eMail: [vertrieb@hepco-becker.de](mailto:vertrieb@hepco-becker.de)  
[www.hepco-becker.de](http://www.hepco-becker.de)