

CP086B - BMW S 1000 RR '19/'21 "Racing" - lato destro

CP086B - BMW S 1000 RR '19/'21 "Racing" - right side

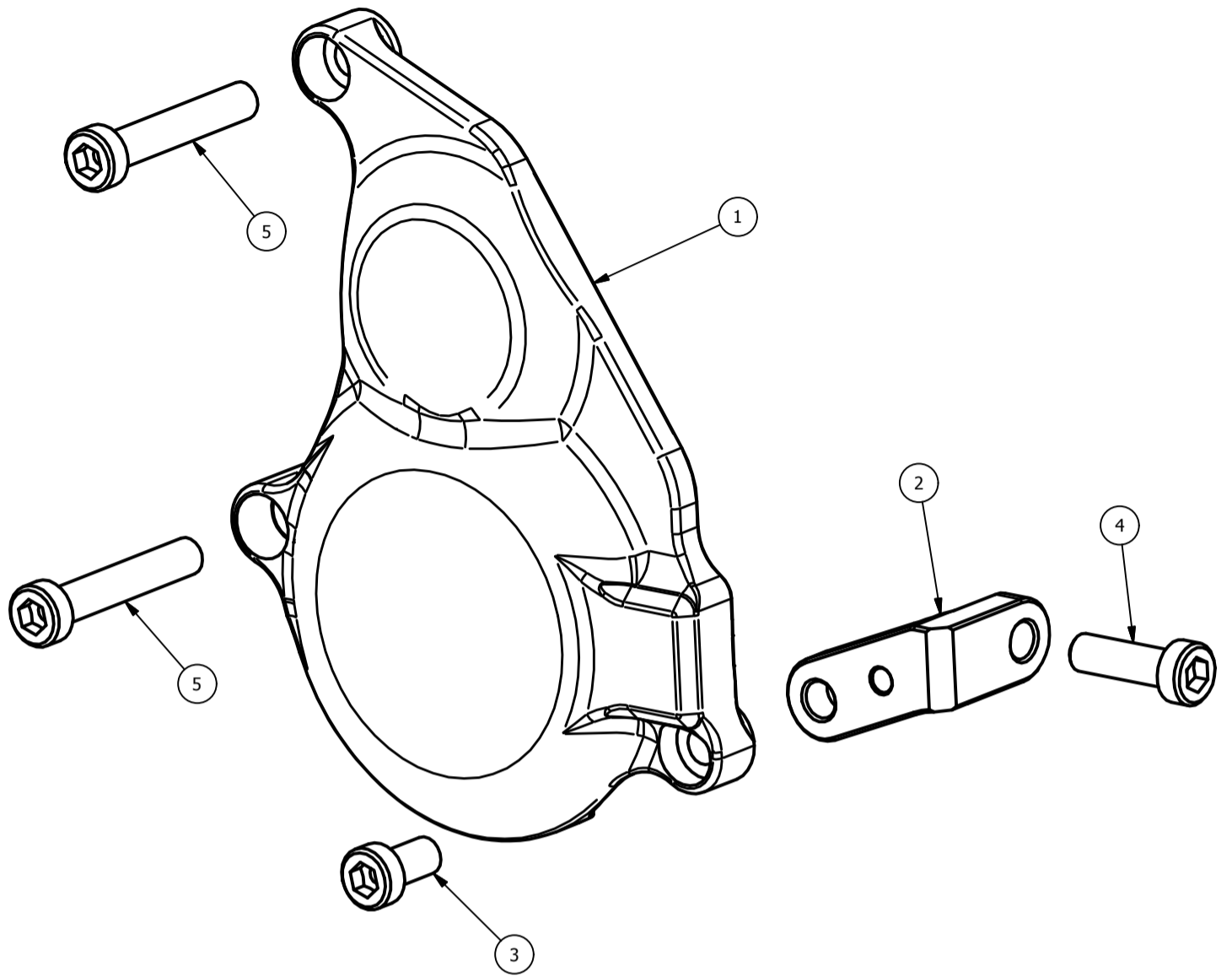

ELENCO PARTI		
ELEMENTO	QTÀ	NUMERO PARTE
1	1	CP084A
2	1	CP084B
3	1	M6x12 TCEI - 10.30 Nm*
4	1	M6x20 TCEI - 10.30 Nm*
5	2	M6x35 TCEI - 10.30 Nm*

*tightening torque - *coppia di serraggio

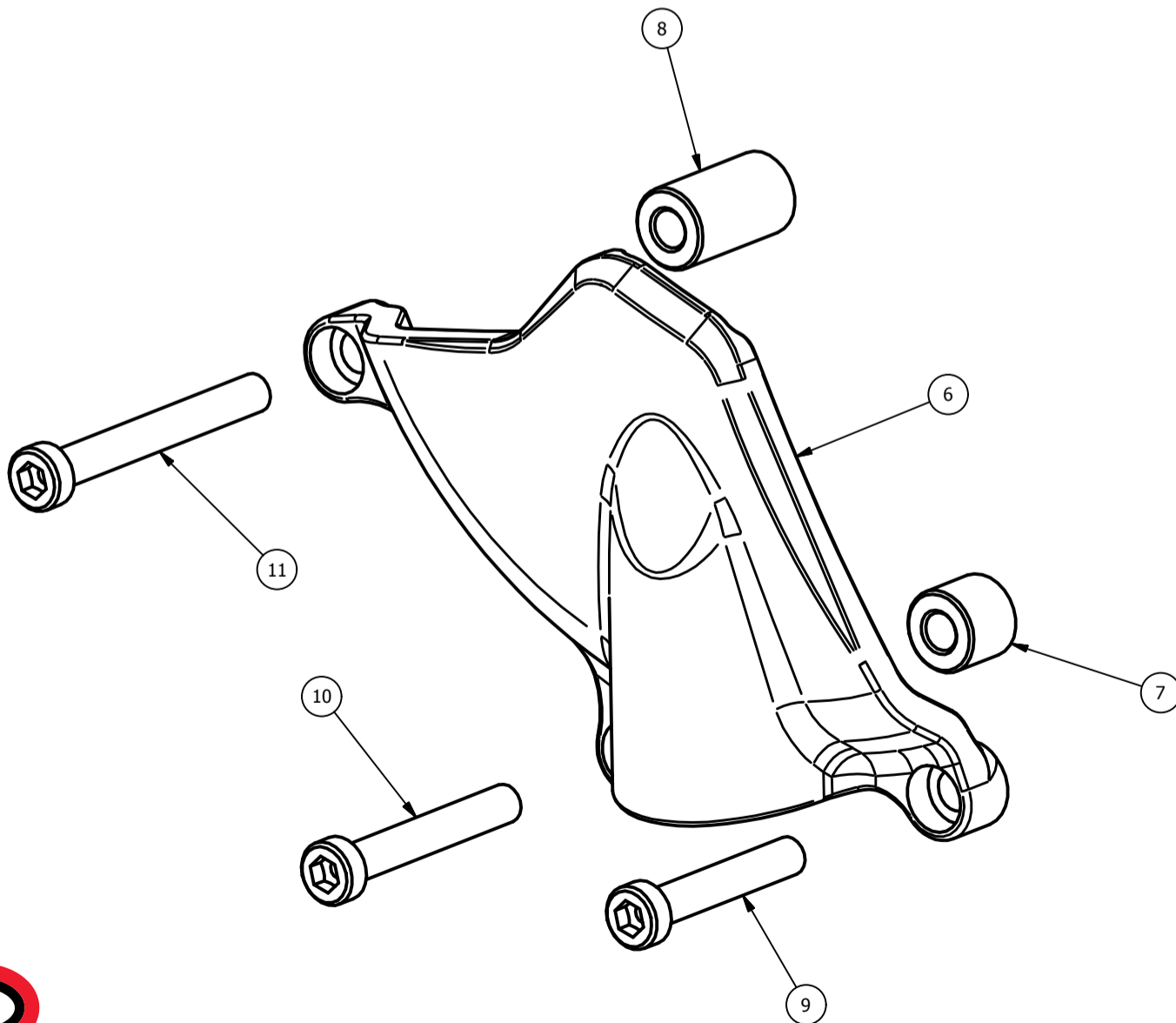

ELENCO PARTI		
ELEMENTO	QTÀ	NUMERO PARTE
6	1	CP085
7	1	spessore 11mm ø13-ø6
8	1	spessore 23mm ø13-ø6
9	1	M6x35 TCEI - 10.30 Nm*
10	1	M6x45 TCEI - 10.30 Nm*
11	1	M6x55 TCEI - 10.30 Nm*

*tightening torque - *coppia di serraggio

CP086B - BMW S 1000 RR '19/'21 "Racing" - lato sinistro

CP086B - BMW S 1000 RR '19/'21 "Racing" - left side

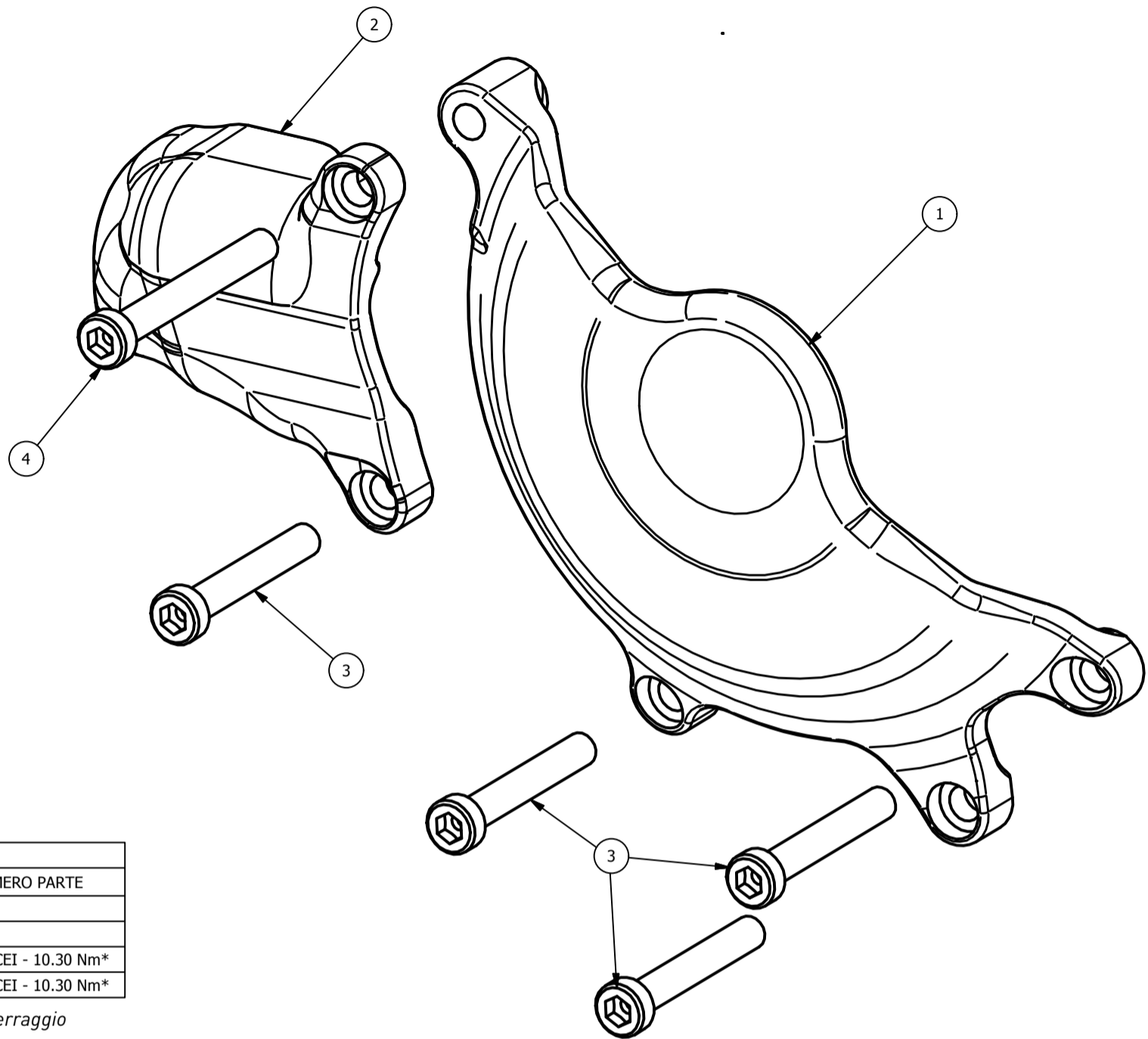

ELENCO PARTI		
ELEMENTO	QTÀ	NUMERO PARTE
1	1	CP082_B
2	1	CP082_C
3	4	M6x40 TCEI - 10.30 Nm*
4	1	M6x55 TCEI - 10.30 Nm*

*tightening torque - *coppia di serraggio

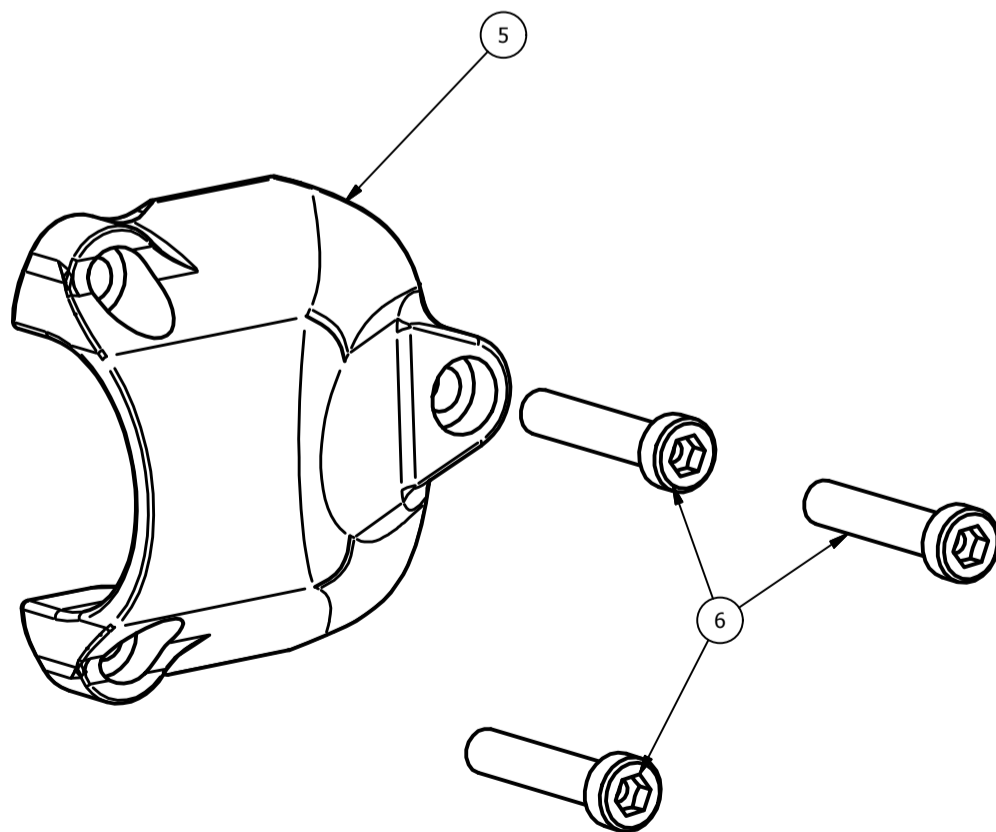

ELENCO PARTI		
ELEMENTO	QTÀ	NUMERO PARTE
5	1	CP083
6	3	M6x30 TCEI - 10.30 Nm*

*tightening torque - *coppia di serraggio