

code K015 - Kawasaki ZX-10R '16/'20

brake side - lato freno

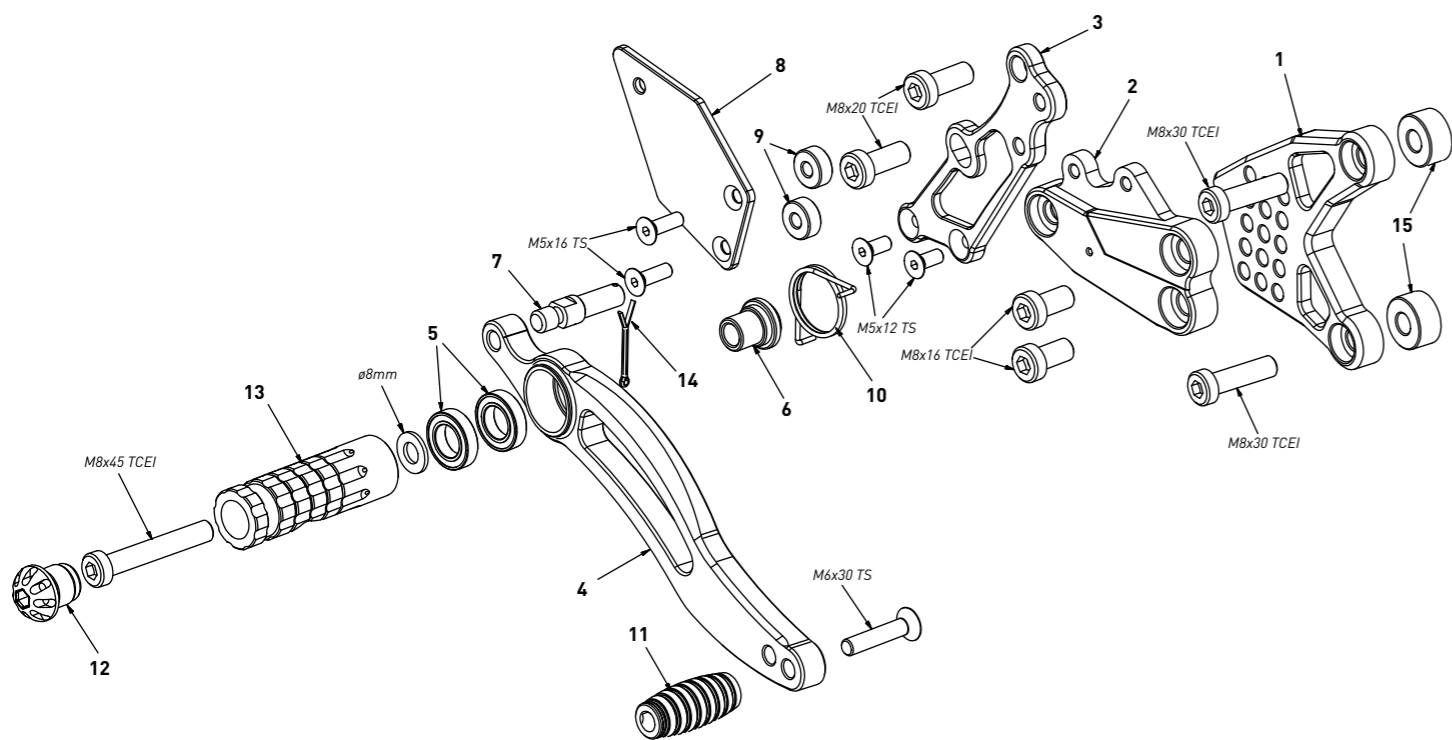

code K015 - brake side - lato freno

n°	description - descrizione	code
1	back plate - arretratore	AR_048
2	plate - piastra	PS_014T
3	pump support - portapompa	PP_026
4	brake lever - leva freno	FN_035
5	bearing - cuscinetto	CS002
6	bush - boccola	BC_002
7	brake pin - perno freno	PF_006
8	heel plate - battitacco	BT_007
9	6mm spacer - spessore 6mm	SP_002
10	spring - molla	MO_002
11	frontpeg - puntalino	PU_001
12	cap - tappo	PG00_BK
13	footpeg - poggia piede	PG03
14	forelock - coppiglia	FN_001
15	12mm spacer - spessore 12mm	SP_009

code K015 - Kawasaki ZX-10R '16/'20

gear side - lato cambio

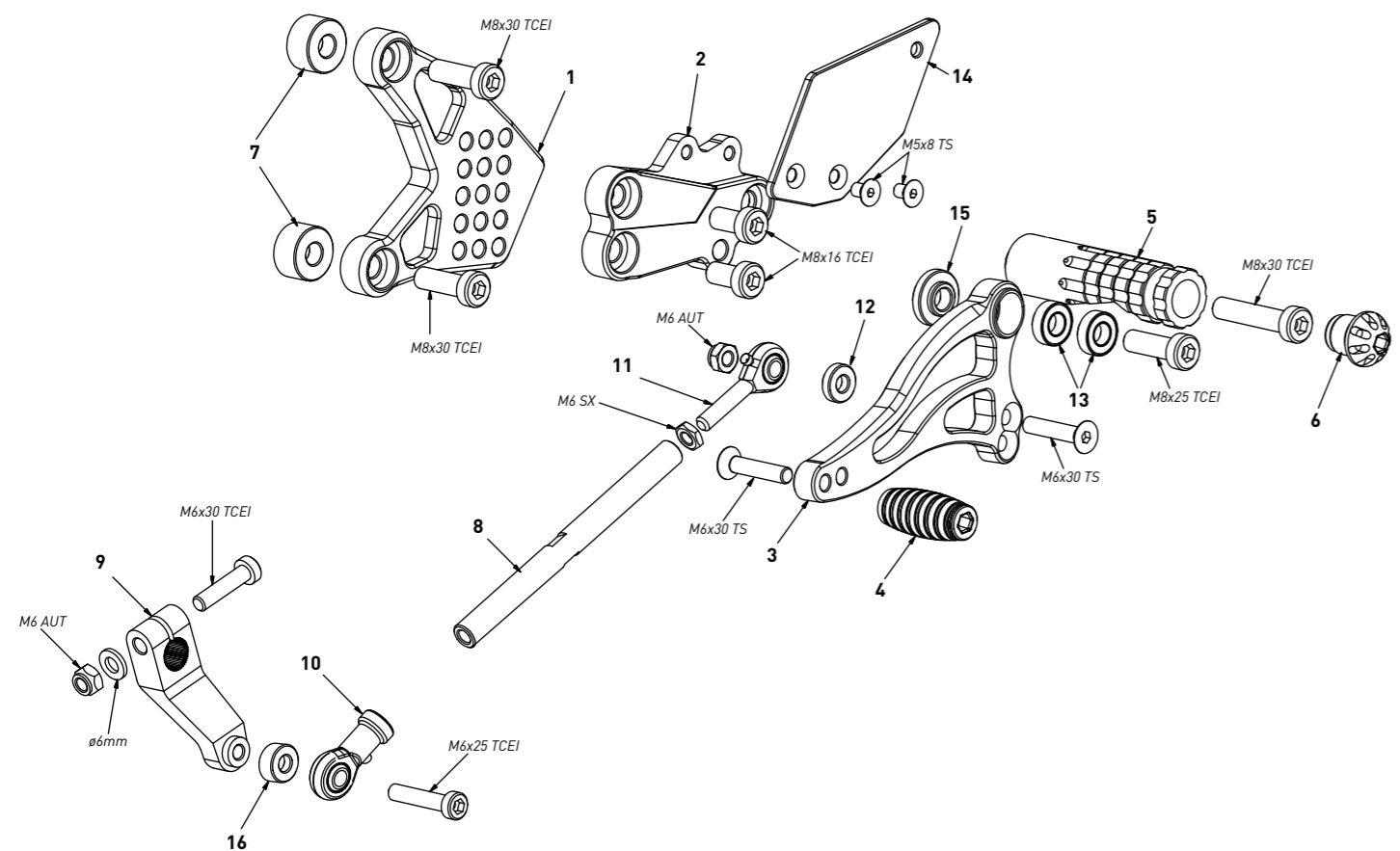

code K015 - gear side - lato cambio

n°	description - descrizione	code
1	back plate - arretratore	AR_047
2	plate - piastra	PS_015T
3	gear lever - leva cambio	LC_036
4	frontpeg - puntalino	PU_001
5	footpeg - poggia piede	PG04
6	cap - tappo	PG00_BK
7	12mm spacer - spessore 12mm	SP_009
8	gear rod - asta cambio	R021_95
9	gear selector - selettore	SC_001
10	RH uniball - uniball DX	RH02_DX
11	LH uniball - uniball SX	RH01_SX
12	3mm spacer - spessore 3mm	SP_003
13	bearing - cuscinetto	CS001
14	heel plate - battitacco	BT_008
15	bush - boccola	BC_001
16	6mm spacer - spessore 6mm	SP_015