

code K017 - Kawasaki Z900 '17/'19

brake side - lato freno

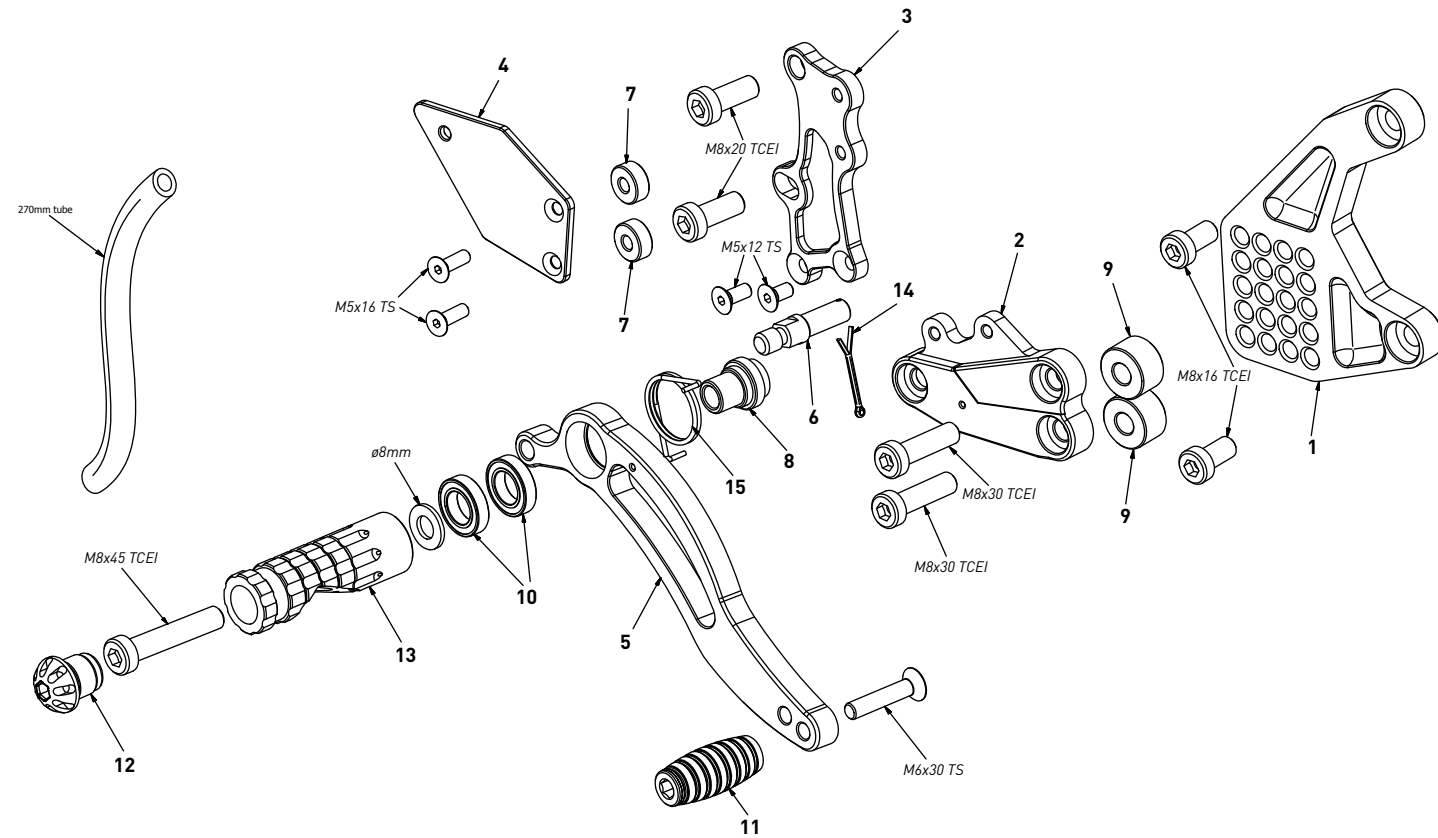

code K017 - brake side - lato freno

n°	description - descrizione	code
1	back plate - arretratore	AR_124
2	plate - piastra	PS_014T
3	pump support - portapompa	PP_013
4	heel plate - battitacco	BT_007
5	brake lever - leva freno	FN_002
6	brake pin - perno freno	PF_005
7	6mm spacer - spessore 6mm	SP_002
8	bush - boccola	BC_002
9	12mm spacer - spessore 12mm	SP_009
10	bearing - cuscinetto	CS002
11	frontpeg - puntalino	PU_001
12	cap - tappo	PG00_BK
13	footpeg - poggia piede	PG03
14	forelock - coppiglia	FN_001
15	spring - molla	MO_002

code K017 - Kawasaki Z900 '17/'19

gear side - lato cambio

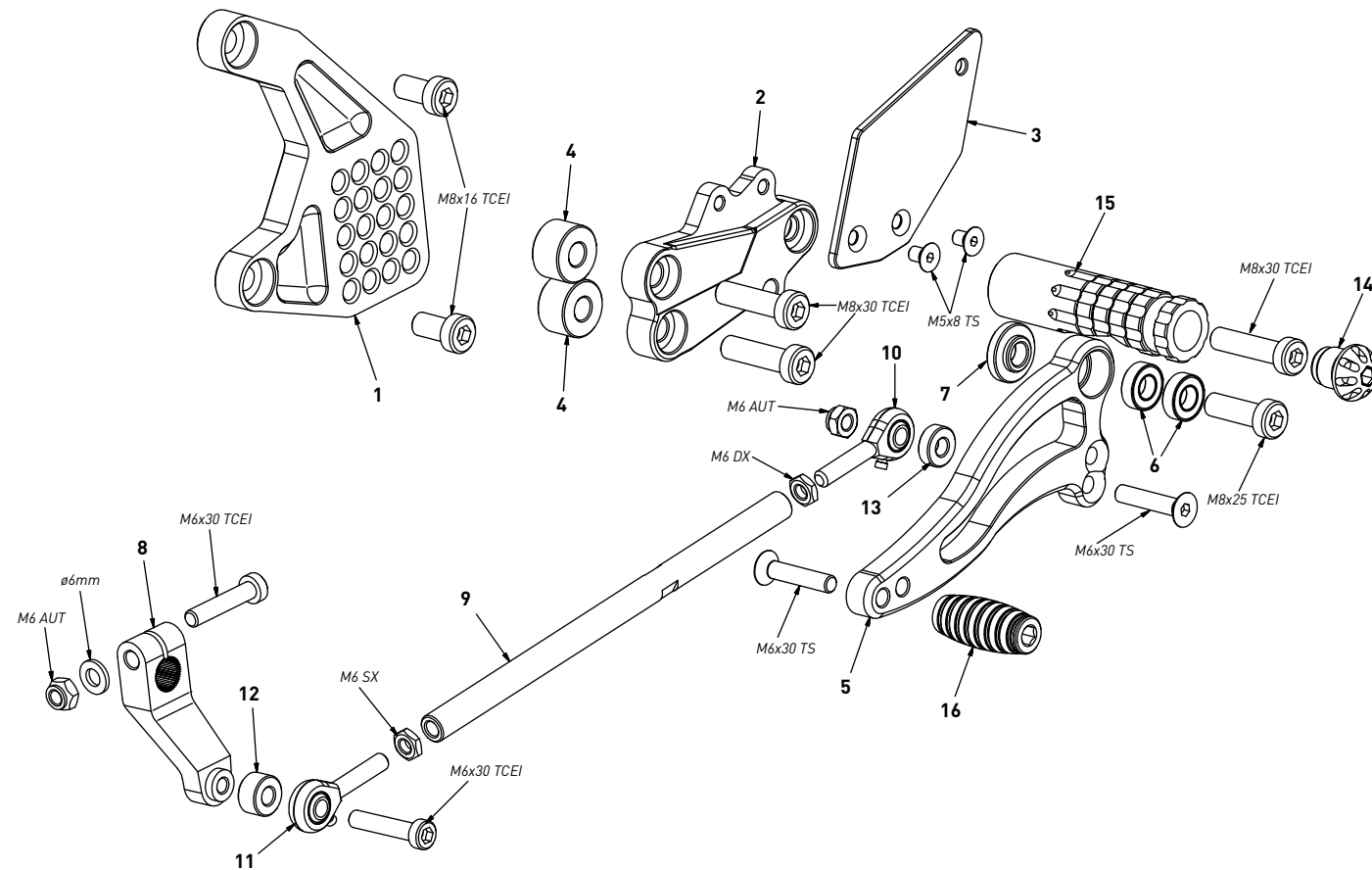

code K017 - gear side - lato cambio

n°	description - descrizione	code
1	back plate - arretratore	AR_123
2	plate - piastra	PS_015T
3	heel plate - battitacco	BT_008
4	12mm spacer - spessore 12mm	SP_009
5	gear lever - leva cambio	LC_007
6	bearing - cuscinetto	CS001
7	bush - boccola	BC_001
8	gear selector - selettore	SC_002
9	gear rod - asta cambio	R021_180
10	RH uniball - uniball DX	RH01_DX
11	LH uniball - uniball SX	RH01_SX
12	8mm spacer - spessore 8mm	SP_016
13	5mm spacer - spessore 5mm	SP_022
14	cap - tappo	PG00_BK
15	footpeg - poggia piede	PG04
16	frontpeg - puntalino	PU_001