

**code K019 - Kawasaki Ninja 250/400 '18/'20**

*brake side - lato freno*

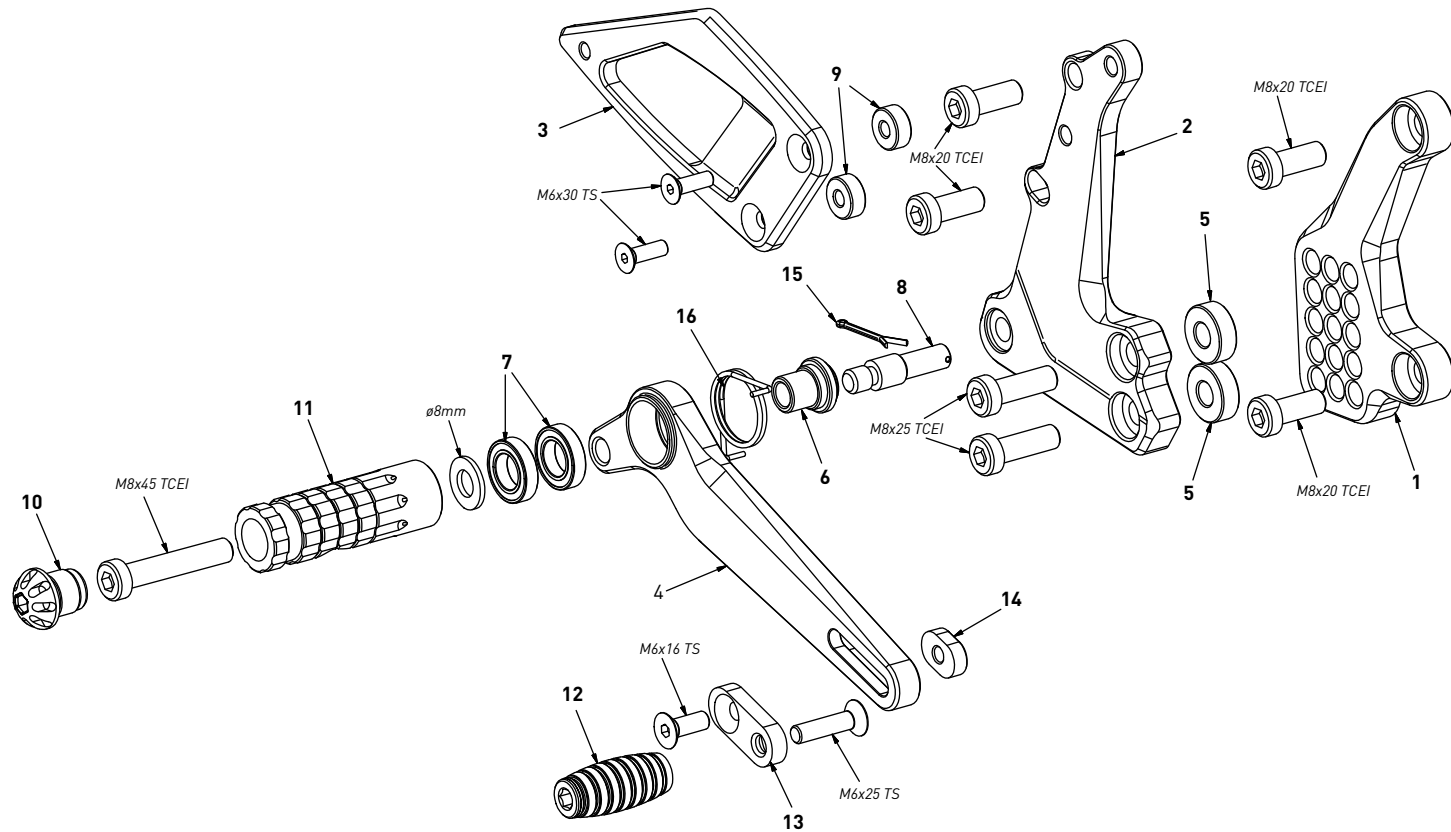

code K019 - brake side - lato freno		
n°	description - descrizione	code
1	back plate - arretratore	AR_126
2	plate - piastra	PS_066T
3	heel plate - battitacco	BT_023
4	brake lever - leva freno	FN_036
5	7mm spacer - spessore 7mm	SP_006
6	bush - boccola	BC_002
7	bearing - cuscinetto	CS002
8	brake pin - perno freno	PF_001
9	6mm spacer - spessore 6mm	SP_015
10	cap - tappo	PG00_BK
11	footpeg - poggiatesta	PG03
12	frontpeg - puntalino	PU_001
13	sliding plate - piastra scorrevole	PU_004
14	anchor - tassello	PU_005
15	forelock - coppiglia	FN_001
16	spring - molla	MO_002

**code K019 - Kawasaki Ninja 250/400 '18/'20**

*gear side - lato cambio*

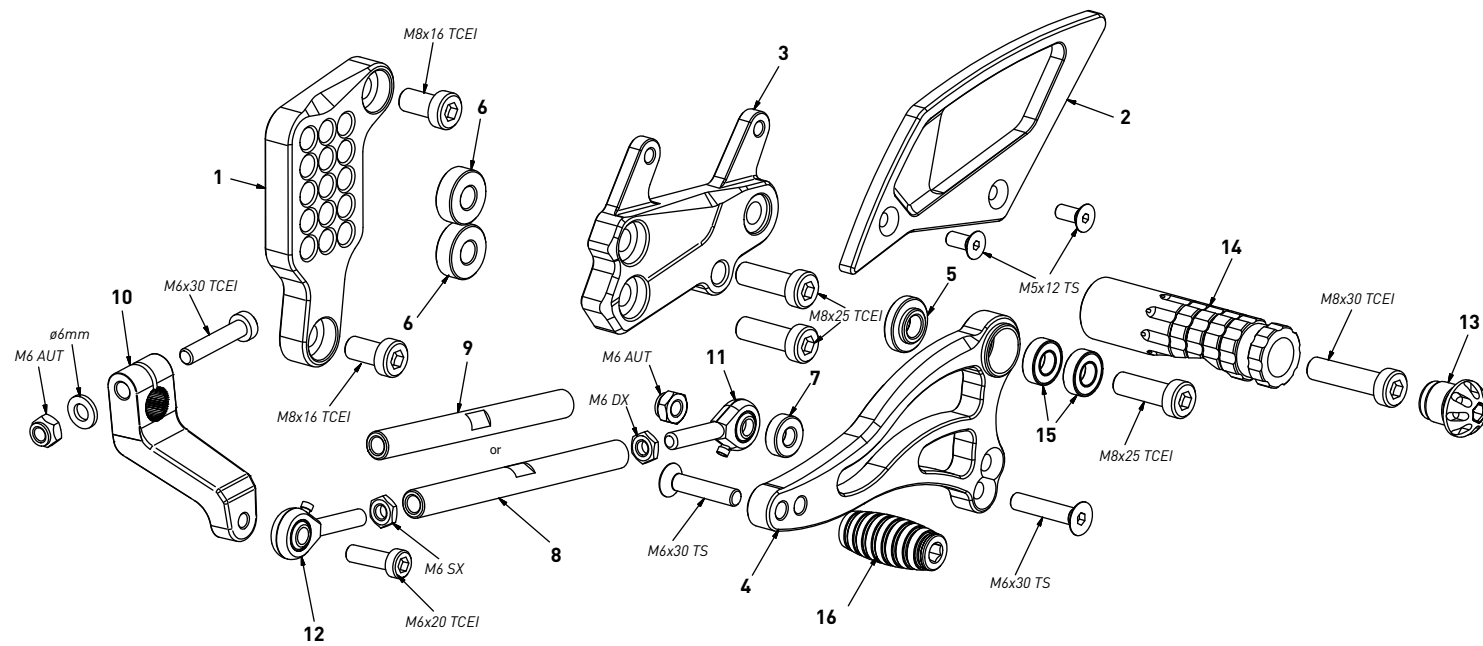

code K019 - gear side - lato cambio		
n°	description - descrizione	code
1	back plate - arretratore	AR_125
2	heel plate - battitacco	BT_022
3	plate - piastra	PS_065T
4	gear lever - leva cambio	LC_036
5	bush - boccola	BC_001
6	7mm spacer - spessore 7mm	SP_006
7	5mm spacer - spessore 5mm	SP_022
8	gear rod - asta cambio	R021_110
9	gear rod - asta cambio	R021_100
10	gear selector - selettore	SC_014
11	RH uniball - uniball DX	RH01_DX
12	LH uniball - uniball SX	RH01_SX
13	cap - tappo	PG00_BK
14	footpeg - poggiatesta	PG04
15	bearing - cuscinetto	CS001
16	frontpeg - puntalino	PU_001