

code KT03 - KTM Superduke 1290 '17/'20

brake side - lato freno

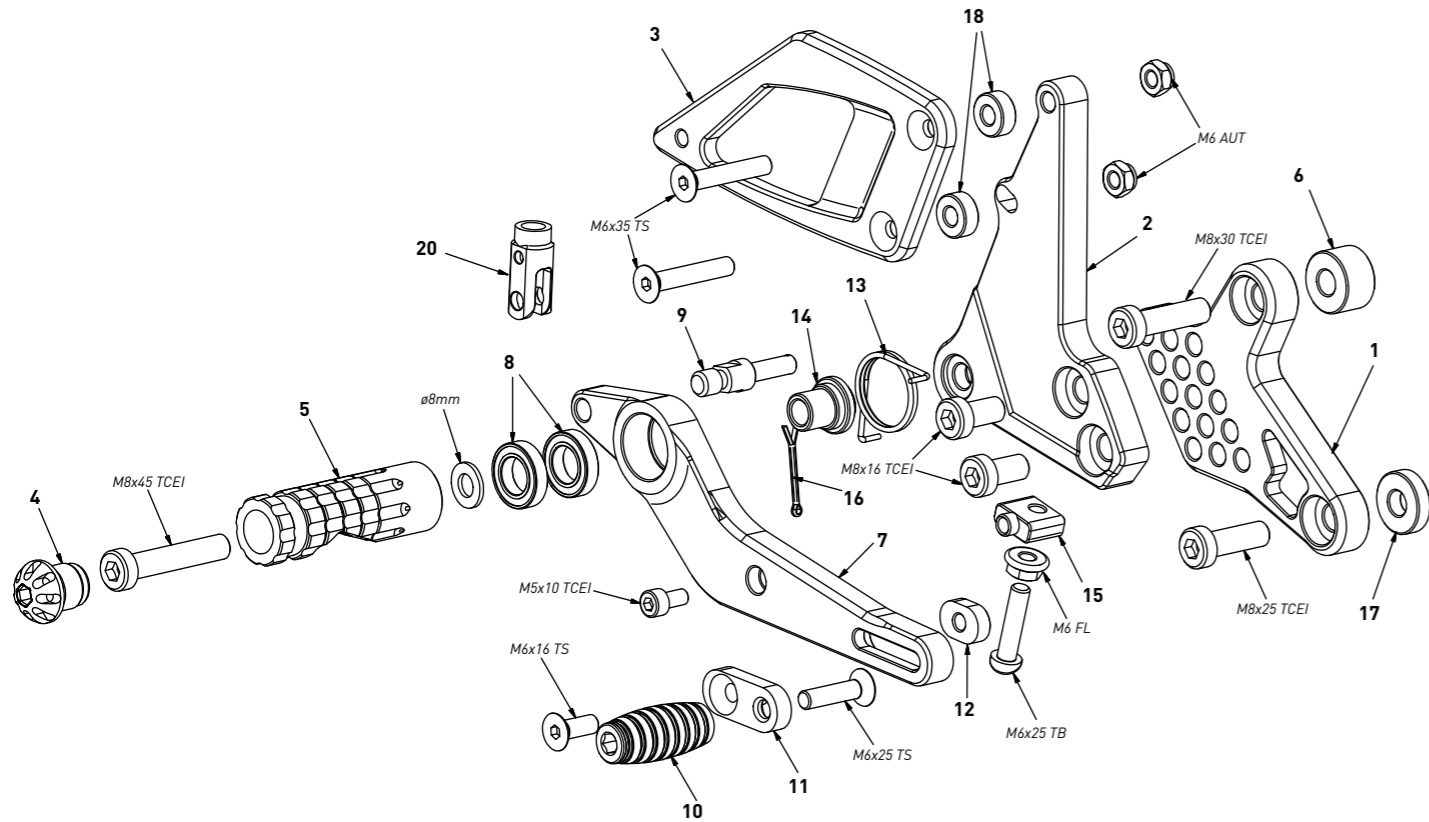

code KT03 - brake side - lato freno		
n°	description - descrizione	code
1	back plate - arretratore	AR_106
2	plate - piastra	PS_056T
3	heelplate - battitacco	BT_023
4	cap - tappo	PG00_BK
5	footpeg - poggiatesta	PG03
6	12mm spacer - spessore 12mm	SP_009
7	brake lever - leva freno	FN_031
8	bearing - cuscinetto	CS002
9	brake pin - perno freno	PF_003
10	frontpeg - puntalino	PU_001
11	sliding plate - piastra scorrevole	PU_004
12	anchor - tassello	PU_005
13	spring - molla	MO_002
14	bush - boccola	BC_002
15	adjuster - registro	FN_025
16	forelock - coppiglia	FN_001
17	5.5mm spacer - spessore 5.5mm	SP_026
18	6mm spacer - spessore 6mm	SP_015
19	adjuster screw - vite registro	FN_014
20	brake pin nut - forchetta	FN_024

code KT03 - KTM Superduke 1290 '17/'20

gear side - lato cambio

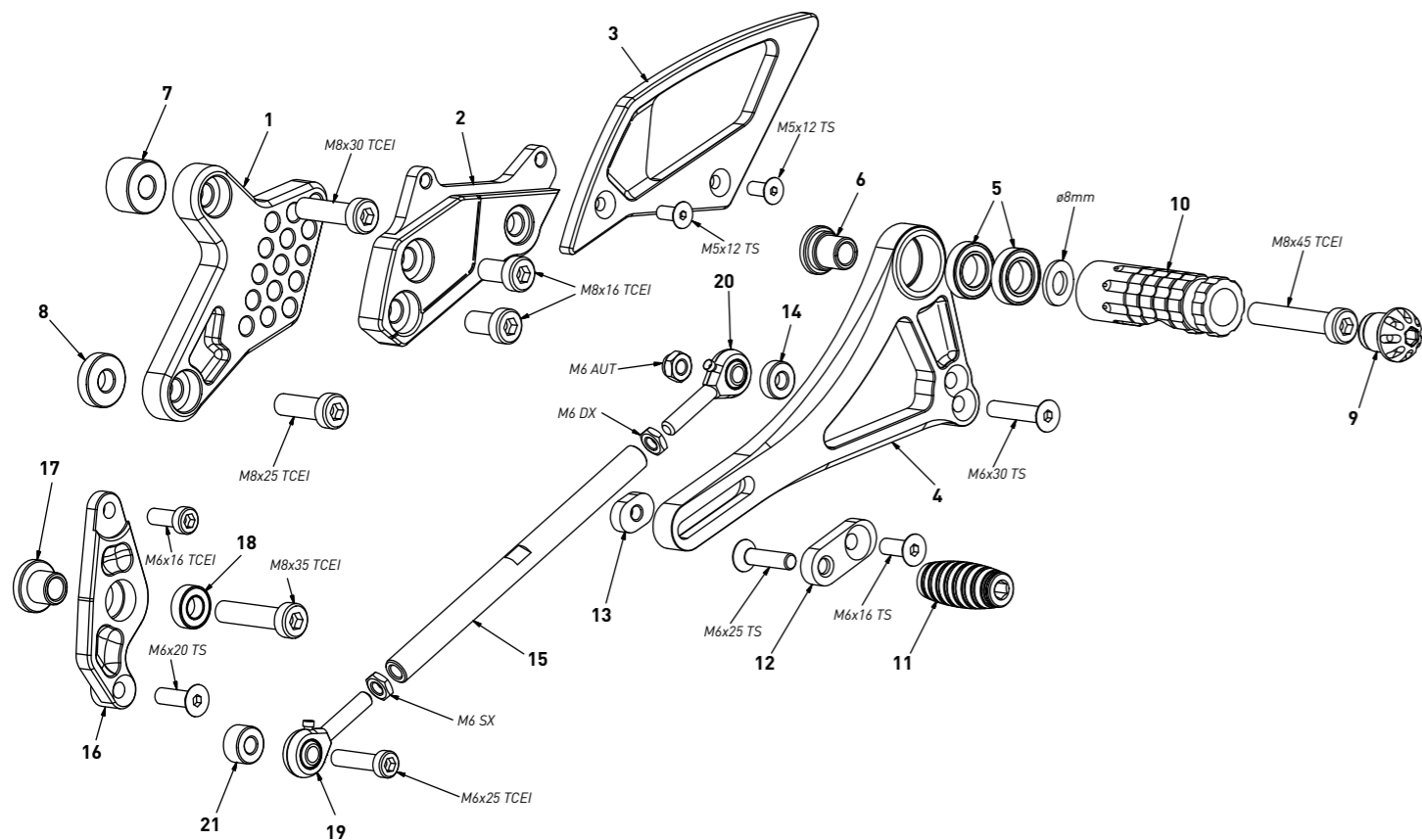

code KT03 - gear side - lato cambio			
n°	description - descrizione	code	
1	back plate - arretratore	AR_105	
2	plate - piastra	PS_043	
3	heel plate - battitacco	BT_022	
4	gear lever - leva cambio	LC_032	
5	bearing - cuscinetto	CS002	
6	bush - boccola	BC_002	
7	12mm spacer - spessore 12mm	SP_009	
8	5.5mm spacer - spessore 5.5mm	SP_026	
9	cap - tappo	PG00_BK	
10	footpeg - poggiatesta	PG03	
11	frontpeg - puntalino	PU_001	
12	sliding plate - piastra scorrevole	PU_004	
13	anchor - tassello	PU_005	
14	5mm spacer - spessore 5mm	SP_022	
15	gear rod - asta cambio	R021_132	
16	gear selector - selettore	SC_012	
17	bush - boccola	DC_038	
18	bearing - cuscinetto	CS001	€ 11,00
19	RH uniball - uniball DX	RH01_DX	€ 16,00
20	LH uniball - uniball SX	RH01_SX	€ 16,00
21	8mm spacer - spessore 8mm	SP_016	€ 4,00