

**code KT04 - KTM 790/890 Duke '18/'20**

*brake side - lato freno*

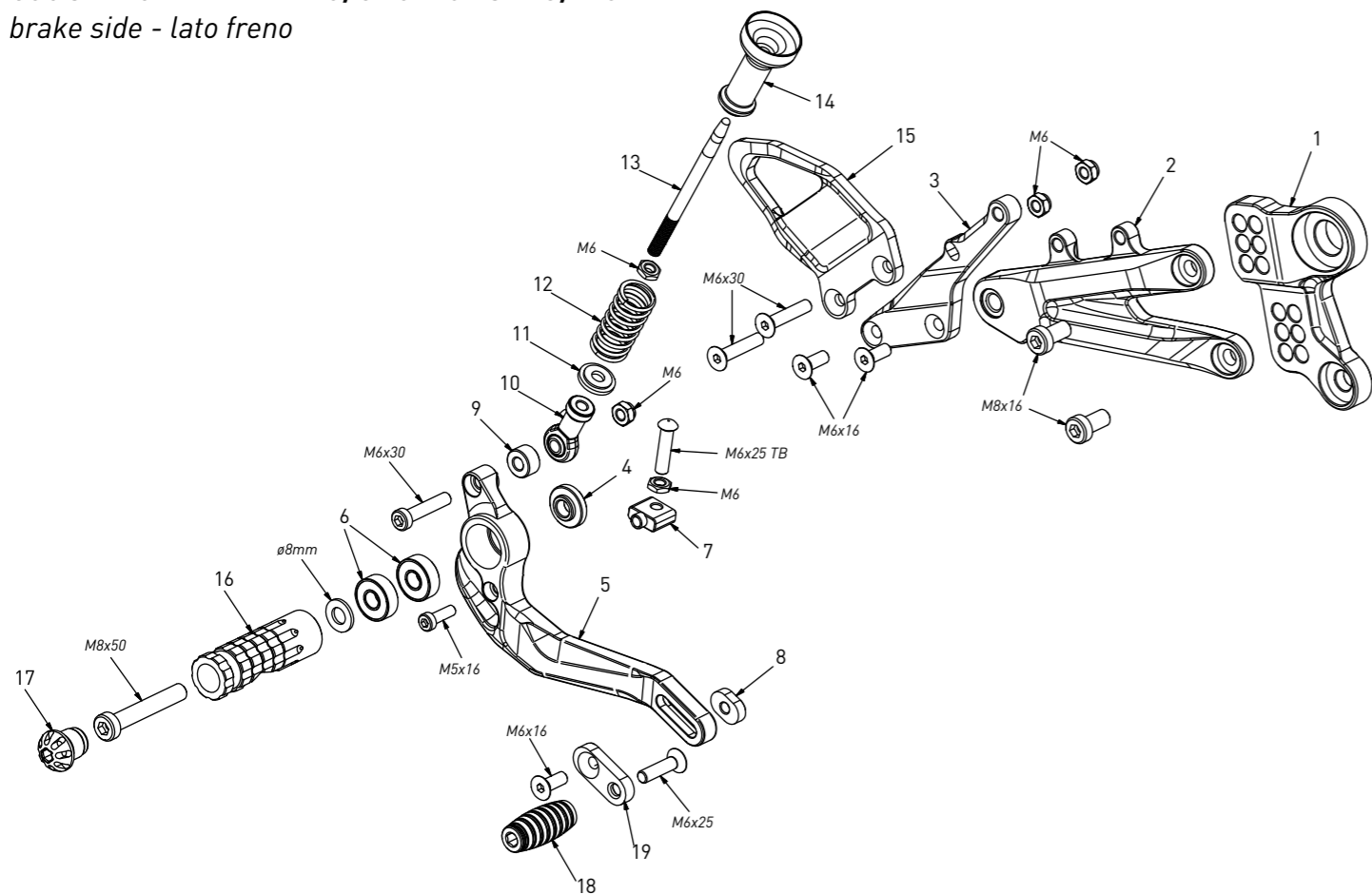

**code KT04 - brake side - lato freno**

n°	description - descrizione	code
1	back plate - arretratore	AR_138
2	plate - piastra	PS_068
3	pump support - portapompa	PP_028
4	bush - boccola	BC_001
5	brake lever - leva freno	FN_037
6	bearing - cuscinetto	CS003
7	adjuster - registro	FN_025
8	anchor - tassello	PU_005
9	8mm spacer - spessore 8mm	SP_016
10	RH uniball - uniball DX	RH02_DX
11	bush - piattello	BC_031
12	spring - molla	MO_003
13	brake pin - perno freno	PF_018
14	pump bush - boccola pompa	BC_029B
15	heelplate - battitacco	BT_040
16	footpeg - poggiatesta	PG03
17	cap - tappo	PG00_BK
18	frontpeg - puntalino	PU_001
19	sliding plate - piastra scorrevole	PU_004

**code KT04 - KTM 790/890 Duke '18/'20**

*gear side - lato cambio*

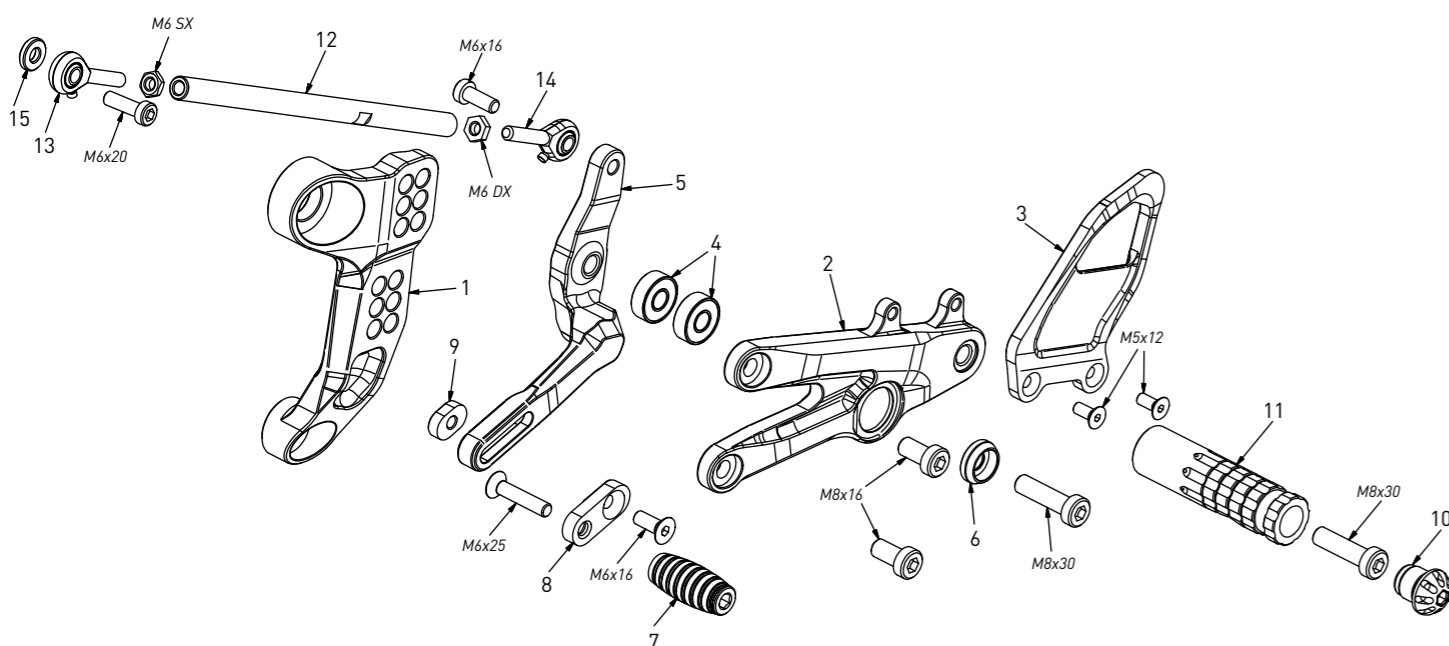

**code KT04 - gear side - lato cambio**

n°	description - descrizione	code
1	back plate - arretratore	AR_137
2	plate - piastra	PS_069B
3	heel plate - battitacco	BT_039
4	bearing - cuscinetto	CS003
5	gear lever - leva cambio	LC_043
6	bush - boccola	BC_030A
7	frontpeg - puntalino	PU_001
8	sliding plate - piastra scorrevole	PU_004
9	anchor - tassello	PU_005
10	cap - tappo	PG00_BK
11	footpeg - poggiatesta	PG04
12	gear rod - asta cambio	R021_185
13	LH uniball - uniball SX	RH01_SX
14	RH uniball - uniball DX	RH01_DX
15	3mm spacer - spessore 3mm	SP_003