

SR310 - KR310

DUCATI MULTISTRADA '03/'05 1000cc

PORTAVALIGIA SPECIFICO - SPECIFIC CASE HOLDER
PORTE-VALESE SP CIRQUE - SPEZIFISCHER KOFFER-IR GER
PORTA-EQUIPAGE ESPECIFICO

ISTRUZIONI DI MONTAGGIO - MOUNTING INSTRUCTIONS
INSTRUCTIONS DE MONTAGE - BAUANLEITUNG - INSTRUCCIONES DE MONTAJE



1
SUPPORTO
SUPPORT
SUPPORT
SUPPORT
SUPPORT

Q.TY n.1

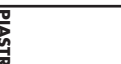

2
PIASTRA MONOKEY
Z222M
PLATE
PLATE
PLATE
PLATE

Q.TY n.1

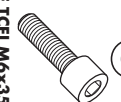

3
VITE TCEI M6x35mm
Screw M6x35mm
VIS M6x35mm
SCHRAUBE M6x35mm
TORNILLO M6x35mm

Q.TY n.4



4
RONDELLA 6mm
WASHER Ø6mm
RONDELLE Ø6mm
ARANDELA Ø6mm

Q.TY n.4



5
DADO A.B. M6
BOLT M6
ECCOU M6
MUTTER M6
TUBERCA M6

Q.TY n.4



6
COPRIFORO
Z621
BOLT CAP
CACHETROU
SCHROLOCK
SCHAUBEN

Q.TY n.6

ATTENZIONE: PESO MASSIMO SOPPORTABILE 10Kg.
WARNING: MAX. LOADING OF THE CARRIER 10Kg.(21lbs)
ATTENTION: CHARGE MAXIMALE 10Kg.
ACHTUNG: MAXIMALE BELASTUNG 10Kg.
¡ATENCIÓN! CARGA MÁXIMA AUTORIZADA 10Kg.

7
RONDELLA 6x18mm
WASHER Ø6x18mm
RONDELLE Ø6x18mm
SCHIBE Ø6x18mm
ARANDELA Ø6x18mm

Q.TY n.4

8
VITE T5CEI M6x45mm
Screw M6x45mm
VIS M6x45mm
SCHRAUBE M6x45mm
TORNILLO M6x45mm

Q.TY n.4

9
VITE T8EI M6x16mm
Screw M6x16mm
VIS M6x16mm
SCHRAUBE M6x16mm
TORNILLO M6x16mm

Q.TY n.4



10
GOMMINO
Z1822
RUBBER
CAOUTCHOUC
GUMMI
GOMA

Q.TY n.4

11
DISTANZIALE fil 1x11mm
Spacer
BREMSE
BREMSE
DISK
DISK

Q.TY n.4

12
RONDELLA IN GOMMA
RUBBER WASHER
RONDELLE EN GOMME
GUMMISCHIBE
ARANDELA DE GOMA

Q.TY n.4

13
RONDELLA 6x20mm
WASHER
RONDELLE
SCHIBE
ARANDELA

Q.TY n.4

14
DISTANZIALE fil 14x30mm
Spacer
BREMSE
BREMSE
DISK
DISK

Q.TY n.4

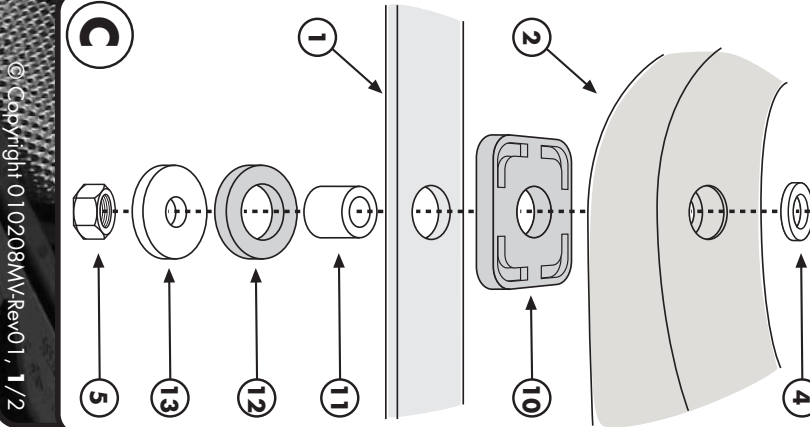
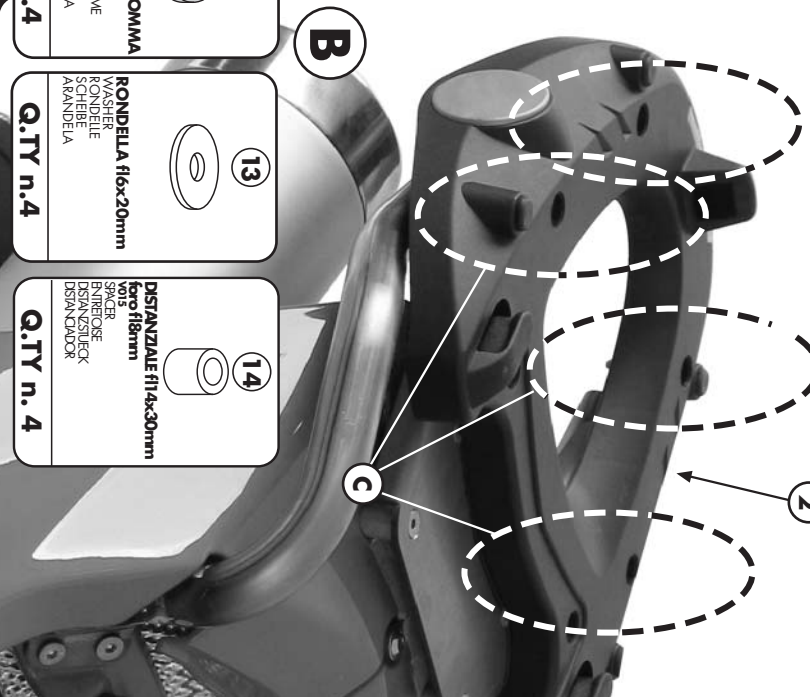
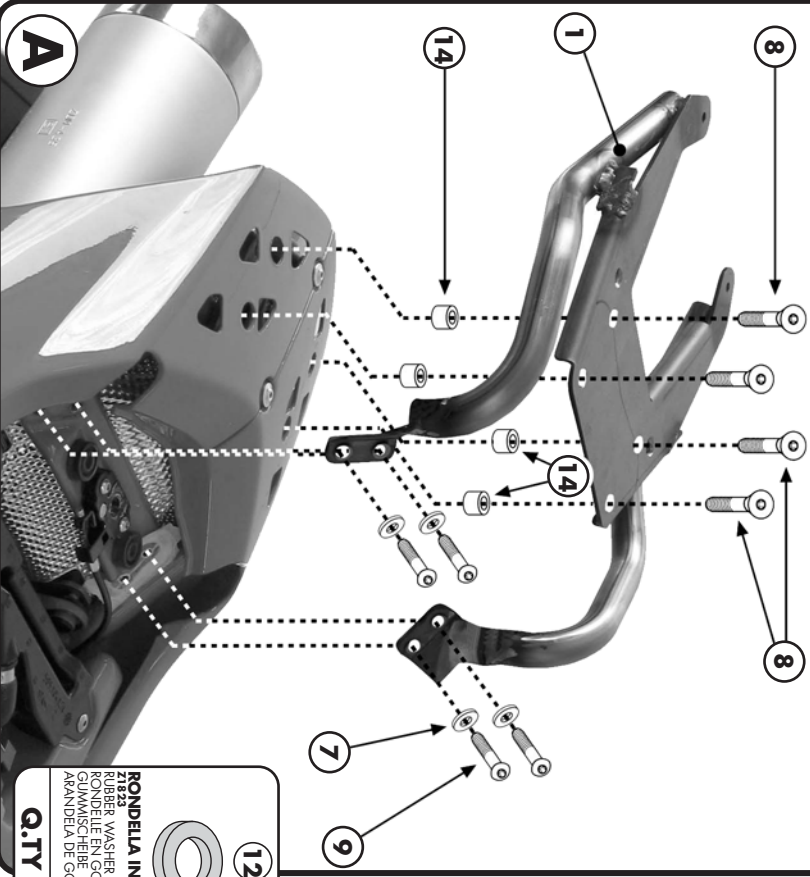

PORTAVALIGIA SPECIFICO - SPECIFIC CASE HOLDER
 PORTE-VALISE SP CIRQUE - SPEZIFISCHER KOFFER-TR GER
 PORTA-EQUIPALE ESPECIFICO

DUCATI MULTISTRADA '03/'05 1000cc

ISTRUZIONI DI MONTAGGIO - MOUNTING INSTRUCTIONS
 INSTRUCTIONS DE MONTAGE - BAUANLEITUNG - INSTRUCCIONES DE MONTAJE

I ISTRUZIONI DI MONTAGGIO

1. SMONTARE IL MANIGLIONE ORIGINALE DALLA CODA DELLA MOTOCICLETTA;
2. TOGLIERE LE GUARNIZIONI IN GOMMA ORIGINALI;
3. POSIZIONARE IL SUPPORTO N°1 COME MOSTRATO IN FOTO A;
4. CONTROLLARE CHE LE VITI SIANO SERRATE BENE;
5. MONTARE LA PIASTRA, PARTICOLARE N°2, COME INDICATO IN FOTO B;
6. ULTIMARE IL MONTAGGIO CONTROLLANDO CHE TUTTE LE VITI SIANO SERRATE BENE.

GB MOUNTING INSTRUCTIONS

1. REMOVE THE ORIGINAL HANDLEBAR OF THE REAR FAIRING;
2. REMOVE THE ORIGINAL RUBBER WASHERS;
3. PLACE THE SUPPORT N° 1 AS SHOWN IN PICTURE A;
4. CHECK THAT THE SCREWS HAVE BEEN TIGHTENED;
5. MOUNT THE PLATE, PART N° 2, AS SHOWN IN PICTURE B;
6. LASTLY CHECK THAT ALL SCREWS ARE TIGHT.

F ISTRUCTIONS DE MONTAGE

1. DEMONTER LES POIGNEES PASSAGER D'ORIGINE DE SUR LA MOTO;
2. ENLEVER LES PROTECTIONS CAOUTCHOU C D'ORIGINE;
3. POSITIONNER LE SUPPORT N°1 COMME MONTRÉ SUR LA PHOTO A;
4. CONTROLER LE BON SERRAGE DES VIS;
5. MONTER LA PLATINE, PIECE N°2, COMME INDIQUE SUR LA PHOTO B;
6. TERMINER LE MONTAGE EN CONTROLANT LE BON SERRAGE DE TOUTES LES VIS.

D BAUANLEITUNG

1. NEHMEN SIE DEN ORIGINAL HANDGRIFF DES FAHRZEUGSHECKS AB;
2. ENTFERNEN SIE DIE ORIGINAL GUMMIDICHTUNGEN;
3. POSITIONIEREN SIE DIE HALTERUNG NR. 1 WIE IM BILD A BESCHRIEBEN;
4. ÜBERPRÜFEN SIE, DASS ALLE SCHRAUBEN FESTGEZOGEN WURDEN;
5. MONTIEREN SIE DIE PLATTE, TEIL NR. 2, WIE IM BILD B BESCHRIEBEN;
6. ZULETZT ZIEHEN SIE ALLE SCHRAUBEN FEST.

ES

INSTRUCCIONES DE MONTAJE

1. DESMONTAR EL ASA ORIGINAL DEL COJÍN DE LA MOTO,
2. QUITAR LA JUNTAS ORIGINALES EN GOMA;
3. MONTAR EL SOPORTE N° 1 COMO ENSEÑA LA FOTO A;
4. CONTROLAR QUE TODOS LOS TORNILLOS ESTEN BIEN APRETADO;
5. MONTAR LA PARRILLA N° 2 COMO INDICA LA FOTO B;
6. TERMINAR APRETANDO TODOS LOS TORNILLOS